

Instruction Manual BGE6007

1. General Discription:

The BGE6007 is a single quadrant controller that contains all the necessary components for driving the BG40, BG62 and BG65 series of brushless DC motors. A single 24V DC-supply is required by the control circuitry and , for most applications by the motor stage as well .If necessary ,the motor stage can also be supplied separately across the full 10VDC to 60 V range .

A compact plastic housing (see fig.1) with a snap-on connector allows for simplified mounting to a DIN-rail and also provides protection against physical damage .All terminations are accessed and achieved via 'Phoenix' style connectors on the front panel.

For torque control applications ,a current limit can be set using an external potentiometer or a 0 to +12V analogue signal.The upper and lower limit of this current range is set via the corresponding potentiometers on the front panel.Similarly ,the motor's speed can also be adjusted using an external potentiometer or a 0 to +10V analogue signal and is regulated by the motor's Hall signals.

Inputs for CW/CCW rotation and Start/Stop are available as standard.Short Circuit braking makes both full speed reversing and rapid braking possible.An output is also available to indicate if the motor is rotating or not .

The controller includes various safety features that can protect the electronic against over-load ,over-voltage and short circuit .

The BGE6007 was designed to provide reliability and performance in a compact and price competitive package.To ensure a `state-of-the-art` switching concept , highly integrated components have been used in conjunction with a PWM MOS-FET power-stage.

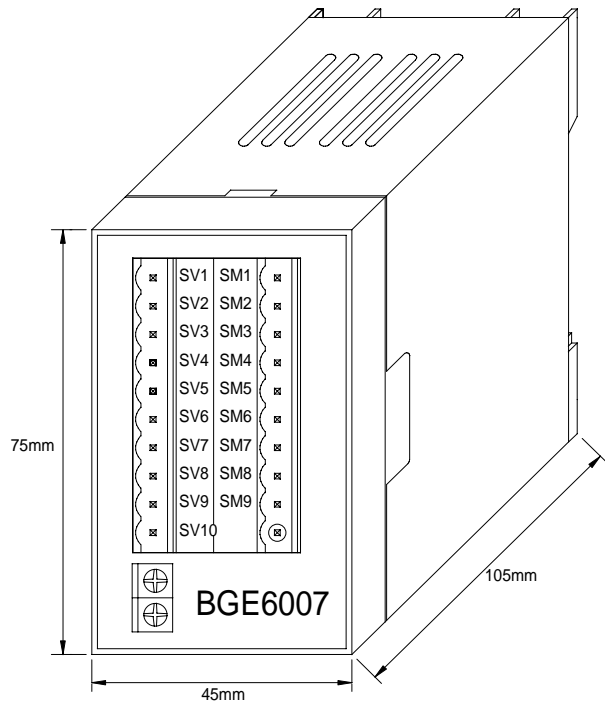

Fig 1: BGE6007 Frontview

2. Technical Details

Operating Voltage

Control circuitry supply voltage	+24VDC
Motor rated supply voltage	+24VDC
Maximum ripple	max.5%
Minimum supply voltage (motor)	+10VDC
Maximum supply voltage (motor)	+60VDC
Over-voltage shutdown	> +65V

Current

Rated current on 24V	7A
Warning: the electronic must be protected with an external fast blow 7A-fuse	
Warning: at higher nominal voltages the available motor current is reduced e.g. adjustable to 3A at +60 V	
Maximum current adjustable	

General technical details

PWM frequency	16kHz
Efficiency	92%
Dimensions in mm	45x75x105
`Phoenix` style connectors	5mm pitch
Speed regulation range	500...5000rpm

Note: The `Phoenix` style connectors used with the BGE6007 are not included in our standard product range .

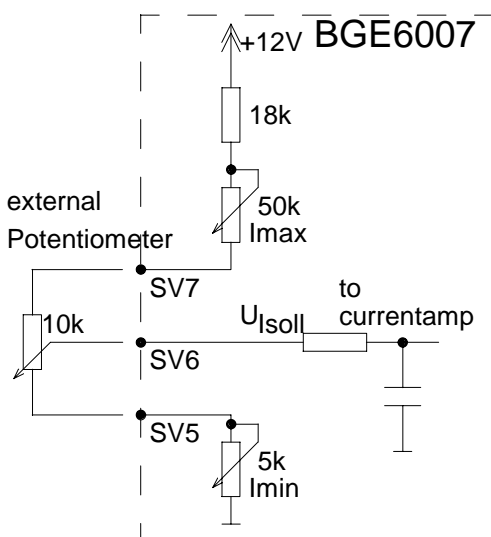

Fig 2: Connection diagram for adjusting the current limit (torque control)using an external

potentiometer .The upper and lower limits of the current range are set using the I_{max} and I_{min} pots. located on the front panel.

3. Pin locations

3.1 Locations 10-pin. supply connector

- SV1** +supply for motor (**+10V...+60V-DC**)
Warning: the electronic must be protected with an external fast blow 7A-fuse
- SV2** +supply for control circuitry (**+24V-DC**)
Warning: the electronic must be protected with an external fast blow 500mA-fuse
- SV3** **GND:** (0V)
- SV4** **STP-OUT:** High-level output indicates that the motor is stationary;**max 50mA**
- SV5** **I-POT-min:** Potitiometer connection for min. Current. **See figure 2 for connection details.** 0...25A
- SV6** **I-POT-m:** current limit input 0...+12V, sensitivity: approx. 0,34V per Amp.
- SV7** **I-POT-max:** Potentiometer connection for maximum current.
- SV8** **Speed:** Input to set speed 0...+10V
- SV9** **Rev:** Direction input.
Low(0V)=CW , High(+24V)=CCW
- SV10** **Run:** Enable-Input. Low(0V)=Stop
High(+24V)=Start

3.2 Locations 9-pin. connector

- SM1** **Mot-B:** Motor phase- B
- SM2** **Mot-A:** Motor phase -A
- SM3** **Mot-C:** Motor phase -C
- SM4** **GND:** (0V)
- SM5** **H1:** Hall-sensor 1
- SM6** **H2:** Hall-sensor 2
- SM7** **H3:** Hall-sensor 3
- SM8** **+12V-DC:** supply for Hall sensors(red)
- SM9** **min-activ:** low(0V)=current limit set on SV6 .High(+24V)=current limit set on potentiometer Poti "Imin"

4. BGE6007 motor connection details

The standard versions of the BG40 and BG62 brushless motors come complete with flying leads. The 2 standard fit connectors on the BG62 (see figure 4) can not be used and must be removed.

The ends of the motor leads should be stripped of insulation, so that they can be screwed into their corresponding locations on the Phoenix style connector and inserted into the controller front panel. Care should be taken to ensure the BG 62's cable shielding (grey lead) is not connected.

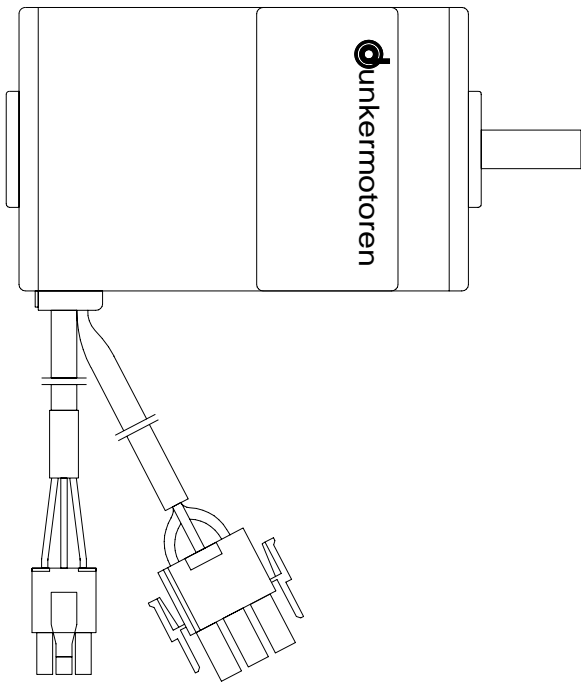

Fig 4: BG62 complete with fitted connectors. These connectors must be removed before connection to the BGE6007.

4.1 Motor connection detail for type BG40

The BG40x25 and BG40x50 motors are each fitted with 30cm long cables. One 3 wire cable for the 3 motor phases and one 5 wire cable for the 3 Hall-sensors and their supply voltages (0V, +12V).

Pin location for the BG40x25 and BG40x50:

3-wire cable for motorphases:

<u>Lead colour</u>	<u>Description</u>	<u>Pin-Location</u>
black:	Motor-phase B	SM1
red:	Motor-phase A	SM2
brown:	Motor-phase C	SM3

5-wire cable for Hall sensors:

<u>Lead colour</u>	<u>Description</u>	<u>Pin location</u>
black:	0V	SM4
yellow:	H1	SM5
green:	H2	SM6
brown:	H3	SM7
red:	+12VDC	SM8

4.2 Motor connection detail BG62

The BG62x30 and BG62x60 motors are each fitted with two 50cm long cables. The 3 motor phases exit the motor separately from the Hall sensor leads. The Hall sensor's cable has a shield that is also terminated onto the 6-pole connector.

Pin location for the BG62x30 and BG62x60:

3-wire cable for motor phases:

<u>Lead colour</u>	<u>Description</u>	<u>Pin location</u>
black/white:	Motor phase-B	SM1
blue/white:	Motor phase-A	SM2
brown/white:	Motor phase-C	SM3

5-wire cable for Hall sensors:

<u>Lead colour</u>	<u>Description</u>	<u>Pin location</u>
black:	0V	SM4
yellow:	H1	SM5
green:	H2	SM6
brown:	H3	SM7
red:	+12VDC	SM8
grey:	shield	n.c.

Instruction Manual BGE6007

5. Connection and operation

5.1 Operation type A1

- Motor supplied with +24V-DC
- Maximum speed
- Peak current set at 25 Amps (not adjustable)*
- Direction switched with S1
- Start/Stop switched with S2

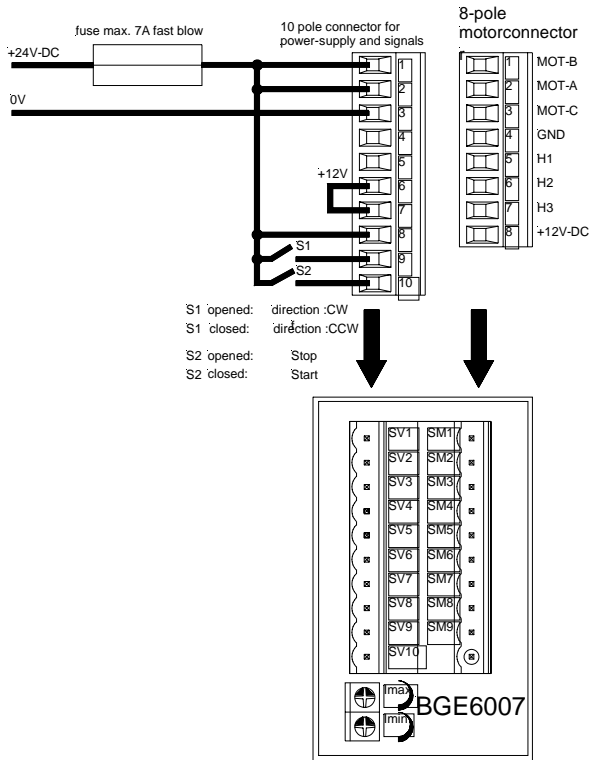

*Note:
By supplying SV6 with +12 V ,the current limit potentiometers become redundant .

5.2 Operation type A2

- Motor supplied with +24VDC
- Maximum speed
- Current limit set via I_{min}^*
- Direction switched with S1
- Start/Stop switched with S2

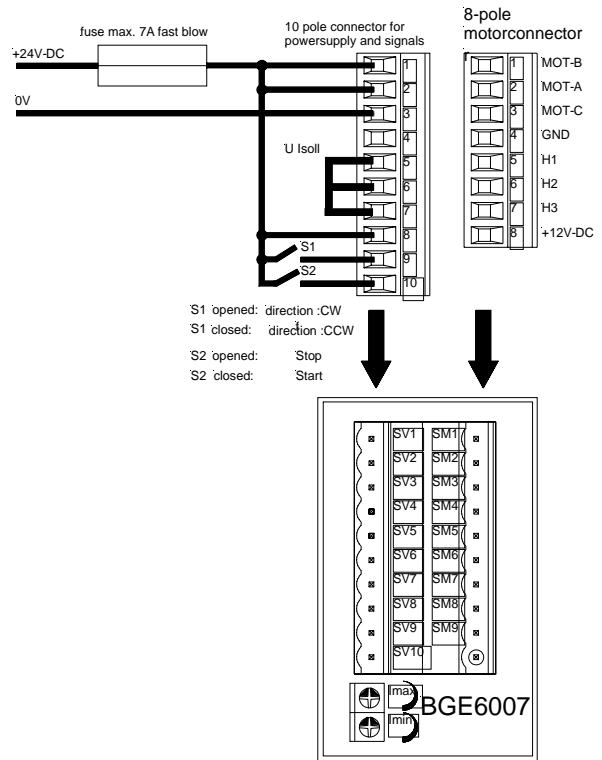

*Note:
Potentiometer "Imin" is used to set the current limit. Depending on the position of the potentiometer "Imax", the current range can be set as follows:
 I_{max} fully cw : $I_{min}=0...2.4A$
 I_{max} fully ccw : $I_{min}=0...7.7A$

5.3 Operation type A3

- Motor supplied with +24VDC
- speed adjustable via Poti P1
- Peak current set at 25 Amps (not adjustable)*
- Direction switched with S1
- Start/Stop switched with S2

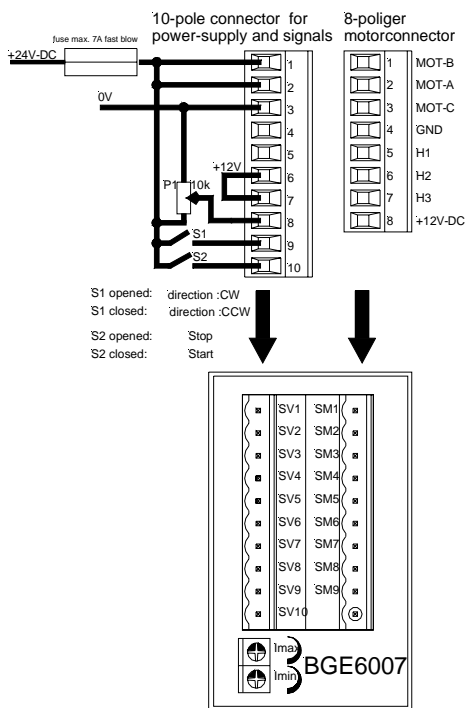

*Note:
 By supplying SV6 with +12V ,the current limit potentiometers becomes redundant .