

NEW

Encoders

magnetic absolute Encoder, advanced SSI Interface,
4096 lines per revolution

For combination with
Brushless DC-Servomotors

Series AESM – 4096

		AESM – 4096	
Lines per revolution	N	4096	
Resolution		12 Bit	
Signal output		Advanced Synchronous Serial Interface (SSI)	
Supply voltage	U _{DD}	4,5 ... 5,5	V DC
Current consumption, typical ¹⁾	I _{DD}	typ. 16, max. 23	mA
Output current, max. (DATA) ²⁾		4	mA
Clock Frequency, max. (CLK)		2	MHz
Input low level (CLK)		0 ... 0,8	V
Input high level (CLK)		2 ... U _{DD}	V
Setup time after power on, max.	t _{setup}	4	ms
Timeout	t _{timeout}	16	µs
Operating temperature range		- 20 ... + 100 °C	

¹⁾ U_{DD} = 5V: with unloaded outputs

²⁾ U_{DD} = 5V: low logic level ≤ 0,4V, high logic level ≥ 4,6V

For combination with motor

Dimensional drawing A	<L1 [mm]		
0824...B	24,1		
Dimensional drawing B	<L1 [mm]		
1028...B	28,1		

Features

The absolute encoder in combination with the Faulhaber motors is ideal for commutation, speed and position control. It can also be used to create a sinusoidal commutation signal.

In the AESM version (absolute encoder), absolute position information is provided with a resolution of up to 4096 steps per revolution at the signal outputs and communicated via a serial (SSI) interface. Absolute means, that each shaft position is assigned to a unique angular value within one revolution. This value is already available directly after power-on.

The advantages are a reduced torque ripple, a higher efficiency, and reduced electrical noise generation. When using sinusoidal commutation. It is also especially suitable for slow speed regulation.

Motor and encoder are connected via a common flexboard.

Circuit diagram / Output signals

Output circuit

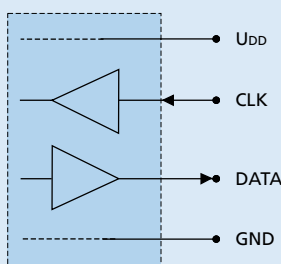

Interface signals (SSI)

Angle position values are ascending for clockwise rotation.
Clockwise rotation as seen from the shaft end.

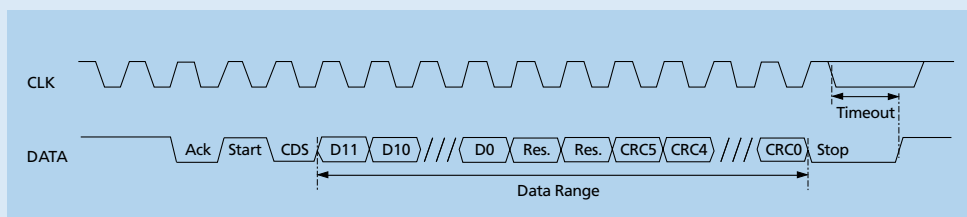

Connector information / Variants

No.	Function
1	Phase C
2	Phase B
3	Phase A
4	GND
5	U _{DD}
6	CLK
7	Reserved
8	DATA

Connection Encoder and Motor

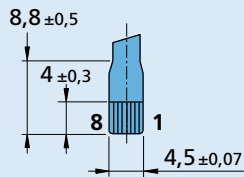

Flexboard
8 circuits, 0,5 mm pitch

Recommended connector
Top contact style
8 circuits, 0,5 mm pitch, e.g.:
Molex: 52745-0896/0897

Full product description

- Examples:
 - 0824K006B AESM-4096
 - 1028S012B AESM-4096

Caution:
Incorrect lead connection will damage the motor electronics!

Dimensional drawing A

Example of combination with 0824...B

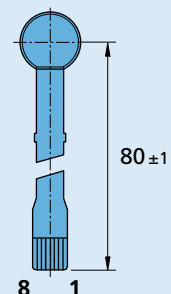
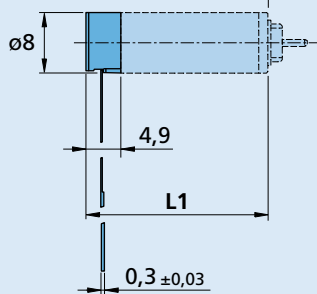

AESM - 4096

Dimensional drawing B

Example of combination with 1028...B

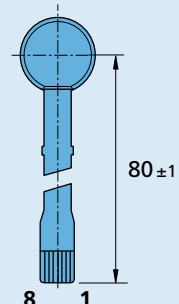
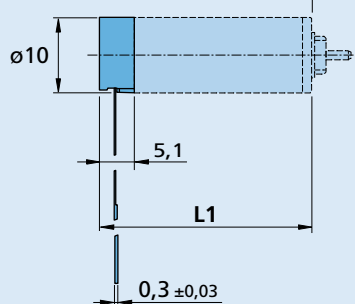

AESM - 4096