

Encoders

optical Encoder, digital outputs,
3 channels, 1000 - 10000 lines per revolution

For combination with
DC-Micromotors
Brushless DC-Motors

Series IER3-10000

	IER3	-1000	-2000	-4000	-1024	-2048	-4096	-1700	-3400	-6800	-2500	-5000	-10000	
Lines per revolution	<i>N</i>	1000	2000	4000	1024	2048	4096	1700	3400	6800	2500	5000	10000	
Frequency range, up to ¹⁾	<i>f</i>	250	500	1000	250	500	1000	250	500	1000	250	500	1000	kHz
Signal output, square wave		2+1 Index												
Supply voltage	<i>U_{DD}</i>	4,5 ... 5,5												
Current consumption ²⁾	<i>I_{DD}</i>	typ. 27, max. 50												
Output current, max. ³⁾	<i>I_{OUT}</i>	4												
Index Pulse width	<i>P₀</i>	90 ± 15												
Phase shift, channel A to B	<i>Φ</i>	90 ± 20												
Signal rise/fall time (C _{LOAD} = 50 pF)	<i>tr/tf</i>	typ. < 0,1 / typ. < 0,1												
Inertia of code disc	<i>J</i>	typ. 0,14												
Operating temperature range		- 20 ... + 85												
Accuracy		typ. 0,3			typ. 0,3			typ. 0,2			typ. 0,1			°m
Repeatability		typ. 0,05												
Hysteresis		< 0,05												
Edge spacing, min.		125												
Mass		typ. 13,5												

¹⁾ Velocity (min⁻¹) = $f(\text{Hz}) \times 60/N$

²⁾ $U_{DD} = 5V$: with unloaded outputs

³⁾ $U_{DD} = 5V$: low logic level < 0,4V, high logic level > 2,4V: TTL compatible

Product combination	IER3	-1000	-2000	-4000	-1024	-2048	-4096	-1700	-3400	-6800	-2500	-5000	-10000	
Series		Motor, <L1 [mm]		Motor, <L1 [mm]		Motor, <L1 [mm]		Motor, <L1 [mm]		Motor, <L1 [mm]		Motor, <L1 [mm]		Drawing
2237 ... CXR		52,5		52,5		-		-		-		-		A
3274 ... BP4		90,5		90,5		-		-		-		-		A
2342 ... CR		60,5		60,5		-		-		-		-		B
2642 ... CXR		60,5		60,5		-		-		-		-		B
2642 ... CR		60,5		60,5		-		-		-		-		B
2657 ... CXR		75,5		75,5		-		-		-		-		B
2657 ... CR		75,5		75,5		-		-		-		-		B
2668 ... CR		86,5		86,5		-		-		-		-		B
3242 ... CR		60,5		60,5		-		-		-		-		B
3257 ... CR		75,5		75,5		-		-		-		-		B
3272 ... CR		90,5		90,5		-		-		-		-		B
3863 ... CR - 2016		82,6		82,6		-		-		-		-		C
3890 ... CR - 2016		108,6		108,6		-		-		-		-		C
2232 ... BX4S		50,2		50,2		50,2		-		-		-		D
2232 ... BX4		50,2		50,2		50,2		-		-		-		D
2250 ... BX4S		68,2		68,2		68,2		-		-		-		D
2250 ... BX4		68,2		68,2		68,2		-		-		-		D
3242 ... BX4		60,0		60,0		60,0		60,0		60,0		60,0		E
3268 ... BX4		86,0		86,0		86,0		86,0		86,0		86,0		E

Characteristics

These incremental encoders with 3 output channels, in combination with the FAULHABER Motors, are used for the indication and control of both shaft velocity and direction of rotation as well as for positioning.

With a reflective code disc two quadrature signal with 90° phase shift and one index impulse per motor revolution are generated.

The optical measurement principle allows high accuracy and repeatability for positioning applications. The high resolution encoder provides up to 4096 lines per revolution. In combination with the brushless DC-Servomotors BX4 with diameter 22 mm up to 6800 lines per revolution are available.

In combination with the brushless DC-Servomotors BX4 with diameter 32 mm up to 10000 lines per revolution are available.

The encoder is connected via a ribbon cable. The pins are compatible to the FAULHABER Encoder IE3.

Circuit diagram / Output signals

Output circuit

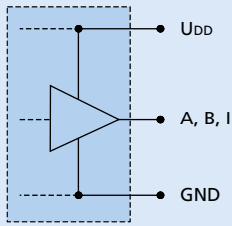

Output signals
with clockwise rotation as seen from the shaft end

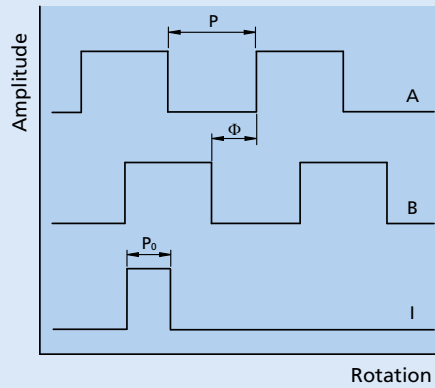

Admissible deviation of phase shift:

$$\Delta\Phi = \left| 90^\circ - \frac{\Phi}{P} * 180^\circ \right| \leq 20^\circ$$

Admissible deviation of Index pulse:

$$\Delta P_0 = \left| 90^\circ - \frac{P_0}{P} * 180^\circ \right| \leq 15^\circ$$

Connector information / Variants

No.	Function
1	N.C.
2	Channel I
3	GND
4	U _{DD}
5	Channel B
6	Channel A

Connection Encoder



Cable
PVC-ribbon cable
6-AWG 28, 1,27 mm

Option

Connector variants AWG 28 / PVC ribbon cable with connector MOLEX Picoblade 51021-0600, recommended mating connector 53047-0610.

Option no.: 3807 for combination with DC-Micromotors series CXR, CR and with brushless DC-Servomotor series 3274...BP4.

Option no.: 3592 for combination with Brushless DC-servomotors series BX4.
Note: inclusive motor connector 3830.



Caution:
Incorrect lead connection will damage the motor electronics!

Full product description

- Example:
2237S012CXR IER3-1024
2232S024BX4 IER3-6800 3592

Dimensional drawing A

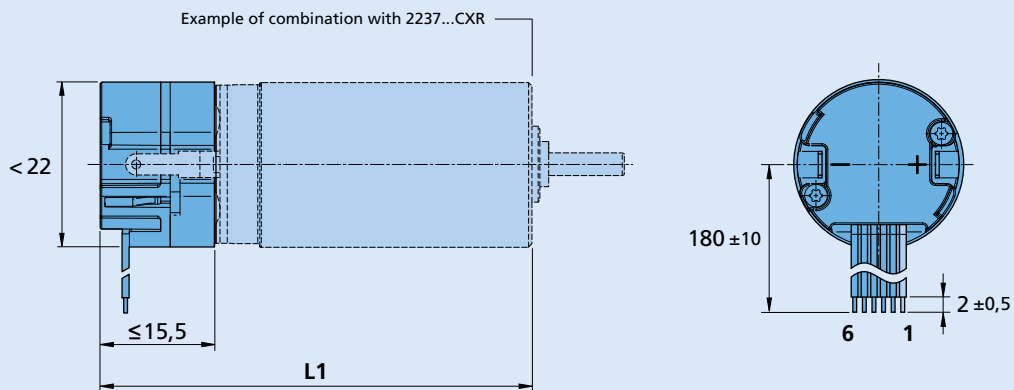

IER3-1000...4096

Dimensional drawing B

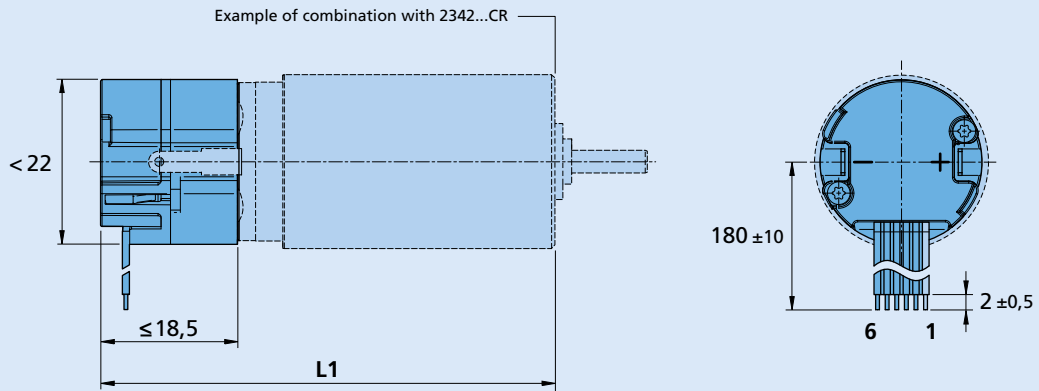

IER3-1000...4096

Dimensional drawing C

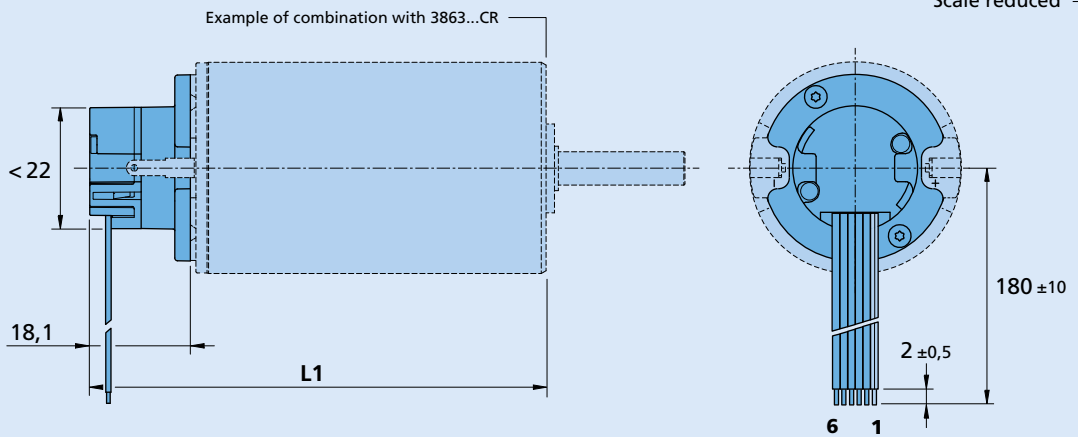

IER3-1000...4096

Dimensional drawing D

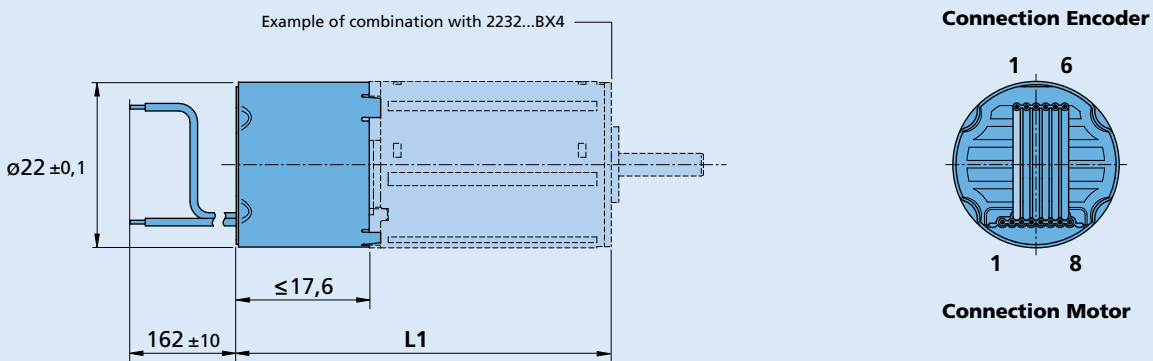

IER3-1000...6800

Dimensional drawing E

