

# Brushless DC-Servomotors

## with integrated Speed Controller

### 4 Pole Technology

## 16 mNm

For combination with  
Gearheads:  
22F, 22/7, 26A

### Series 2232 ... BX4 SC

	2232 S	012 BX4	024 BX4	SC
1 Nominal voltage	$U_N$	12	24	Volt
2 Terminal resistance, phase-phase	R	3,5	12,4	$\Omega$
3 Output power <sup>1)</sup>	$P_{2 \text{ max.}}$	8,8	8,9	W
4 Efficiency	$\eta_{\text{ max.}}$	66,9	67,6	%
5 No-load speed	$n_0$	6 600	7 000	rpm
6 No-load current (with shaft $\varnothing$ 3,0 mm)	$I_0$	0,112	0,061	A
7 Stall torque	$M_H$	55,7	59,9	mNm
8 Friction torque, static	$C_0$	0,85	0,85	mNm
9 Friction torque, dynamic	$C_v$	$1,5 \cdot 10^{-4}$	$1,5 \cdot 10^{-4}$	mNm/rpm
10 Speed constant	$k_n$	579	304	rpm/V
11 Back-EMF constant	$k_E$	1,728	3,288	mV/rpm
12 Torque constant	$k_M$	16,50	31,40	mNm/A
13 Current constant	$k_I$	0,061	0,032	A/mNm
14 Slope of n-M curve	$\Delta n / \Delta M$	123	120	rpm/mNm
15 Terminal inductance, phase-phase	L	120	440	$\mu\text{H}$
16 Mechanical time constant	$\tau_m$	6,7	6,5	ms
17 Rotor inertia	J	5,2	5,2	$\text{gcm}^2$
18 Angular acceleration	$\alpha_{\text{ max.}}$	107	115	$\cdot 10^3 \text{ rad/s}^2$
19 Thermal resistance	$R_{\text{th} 1} / R_{\text{th} 2}$	2 / 13		K/W
20 Thermal time constant	$\tau_{w1} / \tau_{w2}$	4,1 / 283		s
21 Operating temperature range		- 40 ... + 85		$^{\circ}\text{C}$
22 Shaft bearings		ball bearings, preloaded		
23 Shaft load max.:				
– radial at 3 000 rpm (4 mm from mounting flange)		20		N
– axial at 3 000 rpm		2		N
– axial at standstill		20		N
24 Shaft play:				
– radial	$\leq$	0,015		mm
– axial	$\equiv$	0		mm
25 Housing material		stainless steel		
26 Weight		77		g
27 Direction of rotation		electronically reversible		
28 Number of pole pairs		2		
<b>Recommended values - mathematically independent of each other</b>				
29 Speed up to	$n_{e \text{ max.}}$	14 500	8 500	rpm
30 Torque up to <sup>1) 2)</sup>	$M_{e \text{ max.}}$	13 / 16	12 / 13	mNm
31 Current up to <sup>1) 2)</sup>	$I_{e \text{ max.}}$	1 / 1,4	0,5 / 0,8	A

<sup>1)</sup> at 5 000 rpm

<sup>2)</sup> thermal resistance  $R_{\text{th} 2}$  not reduced / thermal resistance  $R_{\text{th} 2}$  by 55% reduced

#### Note:

The diagram indicates the recommended speed in relation to the available torque at the output shaft for a given ambient temperature of 22°C.

The diagram shows the motor in a completely insulated as well as thermally coupled condition ( $R_{\text{th} 2}$  55% reduced).

The motor is factory pre-configured to a continuous current for the thermally insulated condition. The controller must be reconfigured with the easy to use Motion Manager Software for use with other parameter settings.

The nominal voltage ( $U_N$ ) curve shows the operating point at nominal voltage in the insulated and thermally coupled condition. Any points of operation above the curve at nominal voltage will require a higher operating voltage. Any points below the nominal voltage curve will require less voltage.

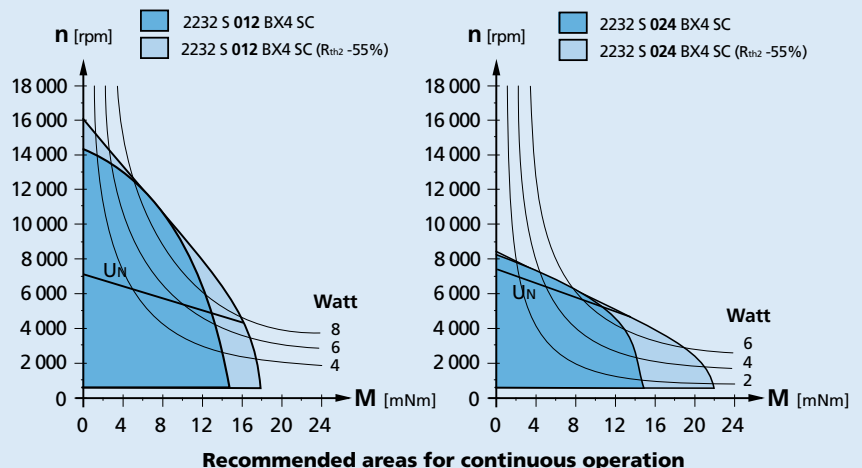

### Dimensional drawing

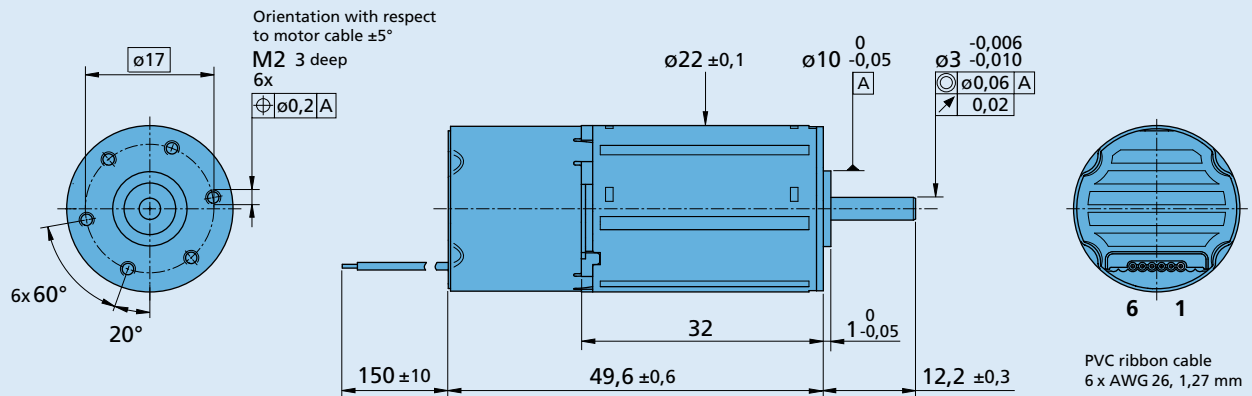

2232 S ... BX4 SC

Speed Controller		012 BX4	024 BX4	SC
Power supply electronic	$U_p$	5 ... 28		V DC
Power supply motor	$U_{mot}$	6 ... 28		V DC
PWM switching frequency	$f_{PWM}$	96		kHz
Efficiency	$\eta$	95		%
Max. continuous output current <sup>1)</sup>	$I_{dauer}$		1,4	A
Max. peak output current <sup>1)</sup>	$I_{max}$		2,8	A
Total standby current at $U_N$	$I_{el}$	0,020		A
Speed range:				
– standard » Hall sensors (digital)		400 ... 50 000 <sup>2)</sup>		rpm
– optional » Hall sensors (analog)		50 ... 50 000 <sup>2)</sup>		rpm
Scanning range		500		$\mu s$

<sup>1)</sup> at 22°C ambient temperature and max. 60°C motor temperature at the nominal voltage of motor and electronics

<sup>2)</sup> speed depend on motor operating voltage

### Connection information

<b>Connection 1 "U<sub>P</sub>":</b>	power supply electronic	$U_p$
<b>Connection 2 "U<sub>mot</sub>":</b>	power supply electronic coil	$U_{mot}$
<b>Connection 3 "GND":</b>	ground	ground
<b>Connection 4 "U<sub>nsoll</sub>":</b>		
– analog input	input voltage	$U_{in} = 0 \dots 10 \text{ V} \mid > 10 \text{ V} \dots U_p$ » set speed value not defined
	input resistance	$R_{in} \geq 5 \text{ k}\Omega$
	set speed value	per 1 V, 1 000 rpm
		$U_{in} < 0,15 \text{ V}$ » motor stops
		$U_{in} > 0,3 \text{ V}$ » motor starts
<b>Connection 5 "DIR":</b>		
– digital input	direction of rotation	to ground or level $< 0,5 \text{ V}$ » counterclockwise
		open or level $> 3 \text{ V}$ » clockwise
	input resistance	$R_{in} \geq 10 \text{ k}\Omega$
<b>Connection 6 "FG":</b>		
– digital output	frequency output	max. $U_p$ ; $I_{max} = 15 \text{ mA}$ ; open collector with 22 k $\Omega$ pull-up resistor
		6 lines per revolution

### Features

In this variant, the brushless DC servomotors have an integrated Speed Controller. The motor is commutated using Hall sensors integrated into the motor. Speed control is via a PI regulator.

The Speed Controller has a current limiting device which limits the maximum motor current if the thermal load is too high. Twice the continuous current is possible over a short time.

Using the "FAULHABER Motion Manager" software, the customer can modify the Speed Controller to special conditions of use. The following parameters can be changed: current limit and regulator parameters.

## Circuit diagram/Connection information

### Output circuit

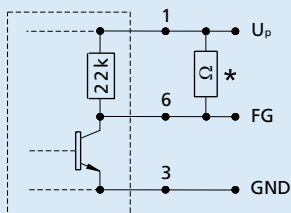

\* An additional external pull-up resistor can be added to improve the rise time.  
 Caution:  $I_{out}$  max. 15 mA must not be exceeded!

### Cable connection

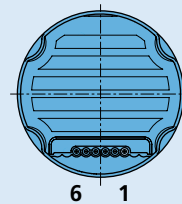

### Connection

No.	Function
1	$U_p$
2	$U_{mot}$
3	GND
4	$U_{soll}$
5	DIR
6	FG

**Caution:**  
 Incorrect lead connection will damage the motor electronics!

### Options

- Connector variant (Option no.: 3809)  
 AWG 26 / PVC ribbon cable with connector Micro-Fit
- Analog Hall sensors (Option no.: 3692)



### Accessories

- Programming board (Part No.: 6501.00088)

### Full product description

- Example:  
 2232S024BX4 SC