

DC-Micromotors

Graphite Commutation

32 mNm
28 W

Series 2642 ... CR

Values at 22°C and nominal voltage		2642 W	012 CR	024 CR	048 CR	
1	Nominal voltage	U_N	12	24	48	V
2	Terminal resistance	R	1,45	5,78	23,8	Ω
3	Output power	$P_{2nom.}$	22,1	23,2	23	W
4	Efficiency, max.	$\eta_{max.}$	78	79	79	%
5	No-load speed	n_0	6 400	6 400	6 400	min ⁻¹
6	No-load current, typ. (with shaft \varnothing 4 mm)	I_0	0,118	0,058	0,029	A
7	Stall torque	M_H	132	139	137	mNm
8	Friction torque	M_R	2	2	2	mNm
9	Speed constant	k_n	565	276	137	min ⁻¹ /V
10	Back-EMF constant	k_E	1,77	3,62	7,31	mV/min ⁻¹
11	Torque constant	k_M	16,9	34,6	69,8	mNm/A
12	Current constant	k_I	0,059	0,029	0,014	A/mNm
13	Slope of n-M curve	$\Delta n / \Delta M$	48,5	46	46,7	min ⁻¹ /mNm
14	Rotor inductance	L	130	550	2 200	μ H
15	Mechanical time constant	τ_m	5,4	5,4	5,4	ms
16	Rotor inertia	J	11	11	11	gcm ²
17	Angular acceleration	$\alpha_{max.}$	120	120	120	$\cdot 10^3$ rad/s ²
18	Thermal resistance	R_{th1} / R_{th2}	2,1 / 11			K/W
19	Thermal time constant	τ_{w1} / τ_{w2}	10 / 510			s
20	Operating temperature range:					
	– motor		-30 ... +125			°C
	– winding, max. permissible		+155			°C
21	Shaft bearings		ball bearings, preloaded			
22	Shaft load max.:					
	– with shaft diameter		4			mm
	– radial at 3 000 min ⁻¹ (3 mm from bearing)		20			N
	– axial at 3 000 min ⁻¹		2			N
	– axial at standstill		20			N
23	Shaft play:					
	– radial	\leq	0,015			mm
	– axial	$=$	0			mm
24	Housing material		steel, black coated			
25	Mass		114			g
26	Direction of rotation		clockwise, viewed from the front face			
27	Speed up to	$n_{max.}$	7 000			min ⁻¹
28	Number of pole pairs		1			
29	Magnet material		NdFeB			
Rated values for continuous operation						
30	Rated torque	M_N	30	32	32	mNm
31	Rated current (thermal limit)	I_N	2,2	1,1	0,56	A
32	Rated speed	n_N	4 390	4 370	4 330	min ⁻¹

Note: Rated values are calculated with nominal voltage and at a 22°C ambient temperature. The R_{th2} value has been reduced by 25%.

Note:

The diagram indicates the recommended speed in relation to the available torque at the output shaft for a given ambient temperature of 22°C.

The diagram shows the motor in a completely insulated as well as thermally coupled condition (R_{th2} 50% reduced).

The nominal voltage (U_N) curve shows the operating point at nominal voltage in the insulated and thermally coupled condition. Any points of operation above the curve at nominal voltage will require a higher operating voltage. Any points below the nominal voltage curve will require less voltage.

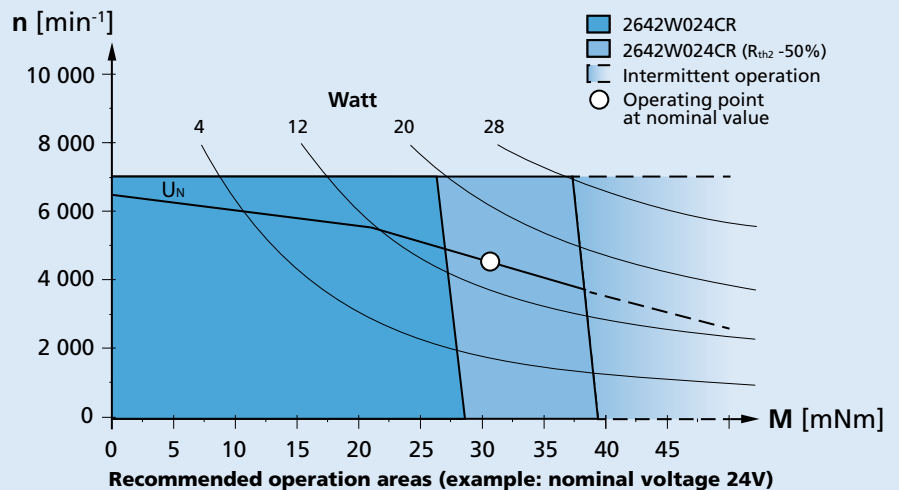

Dimensional drawing

Orientation with respect to motor terminals not defined

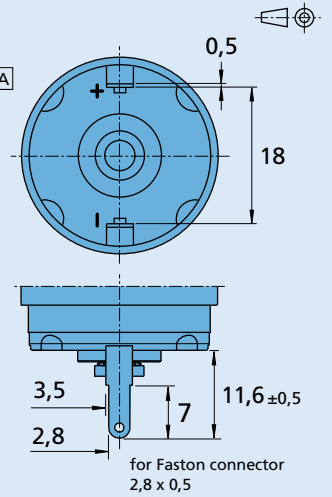
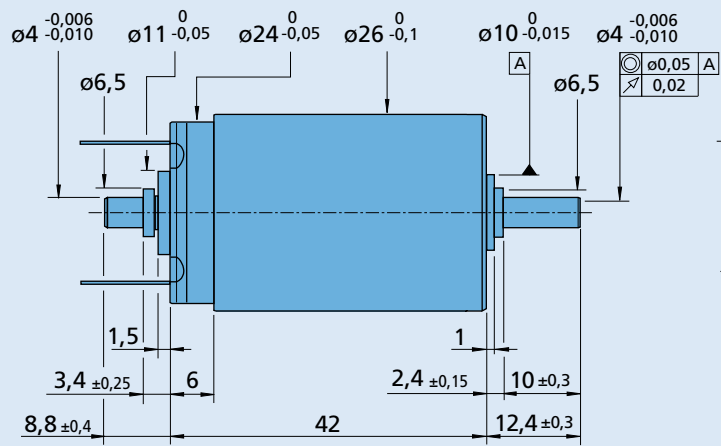
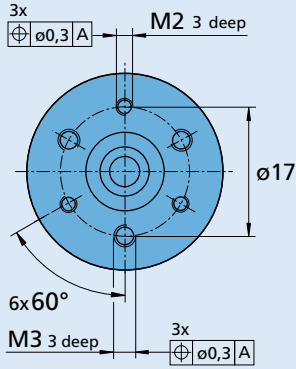

2642 W ... CR

Options

Example product designation: **2642W012CR-158**

Option	Type	Description
U	Single Leads	For motors with single leads (PTFE), length 160 mm, red (+) / black (-)
158	Shaft end	No second shaft end

Product Combination

Precision Gearheads / Lead Screws	Encoders	Drive Electronics	Cables / Accessories
26A 26/1 26/1 S 30/1 30/1 S 32A 32ALN BS22-1.5	HEDS 5500 HEDM 5500 IE3-1024 IE3-1024 L HEDS 5540 HEDL 5540	SC 2402 SC 2804 SC 5004 SC 5008 MCDC 3003 MCDC 3006	MBZ