

Planetary Gearheads

16 Nm

For combination with (overview on page 14-15)
 DC-Micromotors:
 3863
 Brushless DC-Servomotors:
 4490

Series 44/1

	44/1
Housing material	steel
Geartrain material	steel
Recommended max. input speed for:	
– continuous operation	3 500 rpm
Backlash, at no-load	≤ 1°
Bearings on output shaft	preloaded ball bearings
Shaft load, max.:	
– radial (12 mm from mounting face)	≤ 400 N
– axial	≤ 350 N
Shaft press fit force, max.	≤ 500 N
Shaft play (on bearing output):	
– radial	≤ 0,015 mm
– axial	= 0 mm
Operating temperature range	– 30 ... + 125 °C

Specifications

reduction ratio (nominal)	weight without motor	length without motor L2	length with motor		output torque		direction of rotation (reversible)	efficiency
			4490 H L1	3863 H L1	continuous operation M max.	intermittent operation M max.		
4,8 :1	g	mm	mm	mm	Nm	Nm	=	%
23 :1	480	62,2	152,2	126,1	16	20	=	90
111 :1	600	77,8	167,8	141,8	16	20	=	80
531 :1	720	93,2	183,2	157,2	16	20	=	70
2 548 :1	840	108,6	198,6	172,6	16	20	=	65
	960	124,0	214,0	188,0	16	20	=	60

Note: The reduction ratios are rounded, the exact values are available on request.

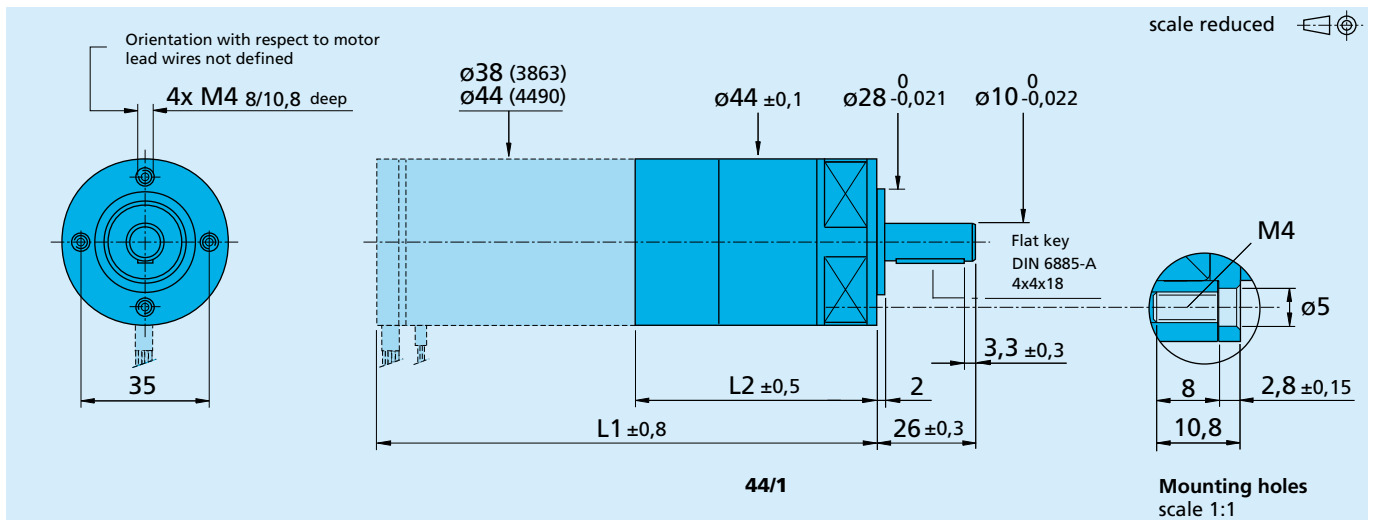

For details on technical information and lifetime performance refer to pages 118-122.

Specifications subject to change without notice.