

- **Support, connect, and power from 1 to 4 Accelus™ Card Servoamplifiers**
- **Connect to DC switching or unregulated power supplies, or transformer secondaries**
- **Sub-D and Euro connectors simplify wiring**

FEATURES

- **Mounts 1 to 4 Copley Controls Accelus™ Card Servoamplifiers**
- **Full-wave-bridge rectifier, filter capacitors, and bleeder resistor provide unregulated DC from a transformer secondary**
- **Screw-terminals for operation from DC power supplies**
- **Compatible with Copley PST series DC power supplies to make complete 4-axis motion subsystem in a 7 x 11.5 in. footprint**
- **OEM custom configurations available to eliminate motion control-card paddleboards & simplify system cabling**

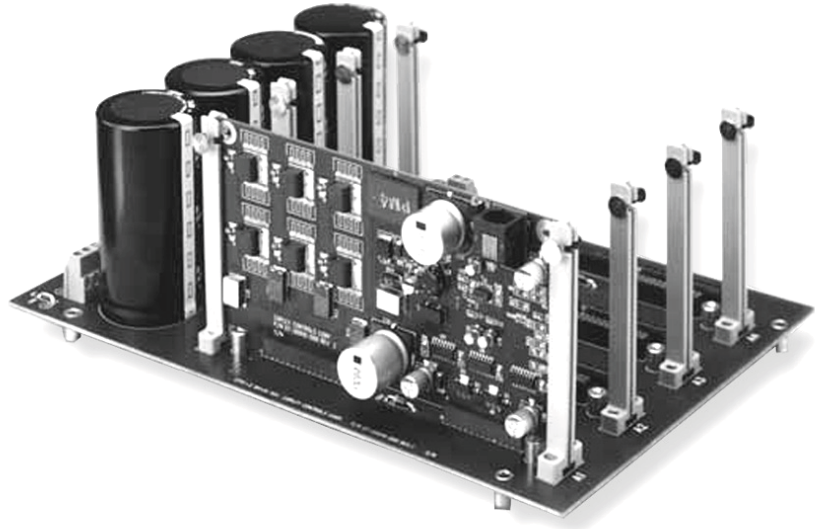

MODEL	SLOTS	AMPLIFIER	I _c	I _p	VDC
SDK-090-04	4	ASC-055-18	6	18	55
		ASC-090-09	3	9	90

DESCRIPTION

The *Accelus™* Development Kit is a companion product to Copley Controls new *Accelus™* Card servoamplifier. It provides mechanical mounting and electrical connections for the amplifier, and includes a rectifier, filter-capacitor, and bleeder resistor on-board to power amplifiers from a transformer secondary.

The on-board bridge rectifier supplies an isolating diode so switching power supplies can be used without becoming unstable due to regeneration effects during deceleration.

The size and mounting points are compatible with Copley Controls' PST series unregulated power supplies. Mounting the SDK to a PST supply puts a four-axis servoamplifier and power source in a 7 x 11.5 in. footprint.

Subminiature-D connectors simplify control system and motor connections to the SDK. Encoder signals are passed from motor connector J2 to signal connector J1, simplifying wiring and eliminating "Y" cables from motor to amp to control system. A Euro style connector is used for motor phase connections, and for power to a motor brake.

A connector for +24V from an external power supply supplies power to motor-mounted brakes. Amplifiers actuate brakes to enable motor rotation and release them when disabled. Fail-safe motor braking occurs when amplifier power is removed. Flyback diodes are included on the SDK pc board to recycle energy stored in motor brake inductance without damaging amplifier outputs.

Accelus™ Card amplifiers are retained by card-guides with locking retainers allowing the SDK to be mounted in any position in user equipment.

A jumper gives users a choice of system ground location. The default connects system ground to the standoffs so that mounting the SDK establishes user frame ground as the default ground reference. Removing the jumper allows users to float SDK ground from frame and connect to equipment ground when desired.

INTRODUCTION

The *Accelus*TM servoamplifier is constructed as a single pc board with edge-connectors for mounting on user pc boards. The *Accelus*TM Development Kit (SDK) provides a convenient means for users to mount, connect, and supply power to from one to four *Accelus*TM servoamplifiers.

A Euro style connector is used for the motor phases, and Sub-D connectors are used for the motor Halls and encoder, and for the amplifier control signals. The SDK is designed for use as a complete mounting and connection means for installation in user equipment, or just for use as a development tool to test the amplifiers before the user pc board is prepared to mount them.

A full-wave bridge-rectifier, filter, and bleeder resistor section on board the SDK enables operation from a simple isolation/step-down transformer. Or, power can be supplied from unregulated, isolated power supplies, or regulated switching power supplies. The on-board rectifier prevents reverse energy from flowing into switching power supplies.

Positive retention of *Accelus*TM amplifiers is provided by locking card guides. The complete SDK can be mounted on Copley PST series power supplies for a complete, four-axis motion control package in an 11.5" x 7" x 7.5" envelope.

SETUP

Setting up the SDK proceeds in three steps:

1. Power source selection and connection
2. Motor connection: U-V-W phases, Halls & encoder
3. Control system connections

These steps are described below

POWER SOURCE SELECTION

The SDK can operate from three types of power-sources:

1. Isolation/step-down transformer secondaries
2. Unregulated, transformer-isolated DC power supplies
3. Regulated, switching power supplies

OPERATION FROM ISOLATION/STEP-DOWN TRANSFORMER SECONDARIES

Selection of a transformer depends upon the model and number of *Accelus*TM amplifiers to be powered, the number of axes, and the power output of each axis. To simplify the process of selection, some typical values of commonly available transformer secondaries are listed below for the two *Accelus*TM models:

ASC-055-18		ASC-090-09	
Vsec	Vdc	Vsec	Vdc
24	31	48	65
30	40	56	77
36	48	60	82

The selections in bold & italics are recommended as they provide for operation at 10% above nominal mains voltage, and allow for 5% change between full-load and no-load voltages.

The maximum VA rating of a transformer to be used with the SDK depends on the secondary voltage, and the current rating

to be used. TB4 has three different current-ratings, depending on the agency approval that is applicable. These are: 24A (IEC DIN/VDE), 15A (UL), and 10A (CSA). Secondary voltage is $(V_{DC} + 2.5)/1.414$, not allowing for high/low line conditions, or power supply ripple and full-load to no-load changes. For example, using the UL rating of 15A, and designing for a DC voltage of 48V, the secondary voltage is 35VAC, and the VA rating of the transformer would be $35 * 15 = 530VA$. The power requirement depends on the number of amplifiers & motors, the actual mechanical power required for each motor, and the duty cycle for each amplifier mounted in the SDK. It is not a simple solution and is beyond the scope of this application note.

But, using the data above, and some rough calculations of the power required, it is a simple matter to buy a transformer and check its' operation in service. The temperature rise is a simple but effective measure of the power demand from it. A cool transformer is clearly overrated, and inversely a high temperature rise would indicate a higher VA-rated model should be used.

The transformer secondary connects to the SDK at TB4. The "X" designation is typically used to label transformer secondary terminals (primary terminals use "H" labels):

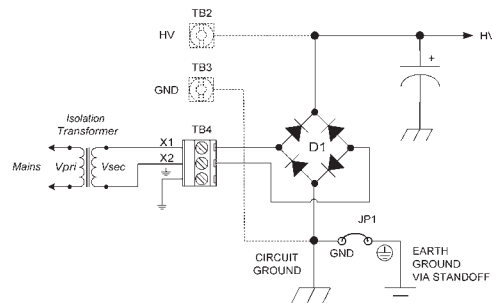

OPERATION FROM UNREGULATED DC POWER SUPPLIES

Terminals TB2 and TB3 connect to the SDK internal +HV buss directly. When using unregulated DC power supplies these connections should be used as they permit current to flow into the SDK when accelerating motors, and to flow out of the SDK when decelerating. In this case, the mechanical energy of the load is passed through the amplifier back into the power supply in a process called *regeneration*. The energy put back into the power supply will cause the buss voltage to increase, or *pump-up*. If the capacitance of the SDK power supply, and that of the external power supply is insufficient to absorb the energy without increasing to the amplifiers shut-down voltage, and external regenerative energy dissipater may be required.

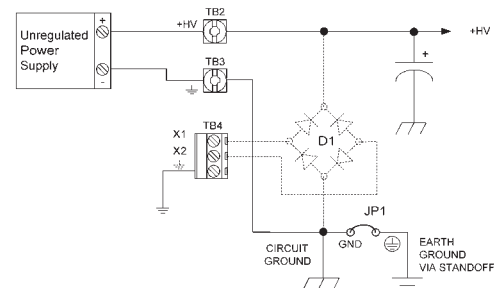

OPERATION FROM DC SWITCHING POWER SUPPLIES

DC switching power supplies are regulated power supplies that use high-speed switches and small ferrite transformers to generate DC power without the bulk of the 50/60 Hz iron transformers used in common unregulated power supplies. They produce high power output from a much smaller volume and weight, but their outputs are designed to drive loads that always sink current. A mechanical system comprised of a motor and a load absorbs power on acceleration, and converts this power to the energy of motion, kinetic energy. When the load is decelerated, this kinetic energy must be dissipated to bring the system to a halt. Servoamplifiers pass energy from the power supply to the load during acceleration, which works well with switching supplies. But, upon deceleration, the same energy (minus losses in the motor resistance and amplifier) pass back through the amplifier and into the power supply. An unregulated supply will simply "pump-up" as the filter capacitors absorb the energy and their voltage rises. But, the switching supply cannot accept energy coming back into its' output. The simple solution to this situation is to put a diode between the switching power supply output that only permits energy to flow from the supply into the load. During deceleration, the capacitors in the SDK absorb the energy (until the amplifiers' shut-down voltage is exceeded) and the full-wave-bridge rectifier

prevents energy flow back into the switching supply.

To connect a switching power supply to the SDK, the positive output must be connected to X1 on TB4, and the negative output must be connected to TB3. This way, the negative terminal will be at circuit ground, and the +HV buss will be about 0.7~1.0V less than the power supply output voltage.

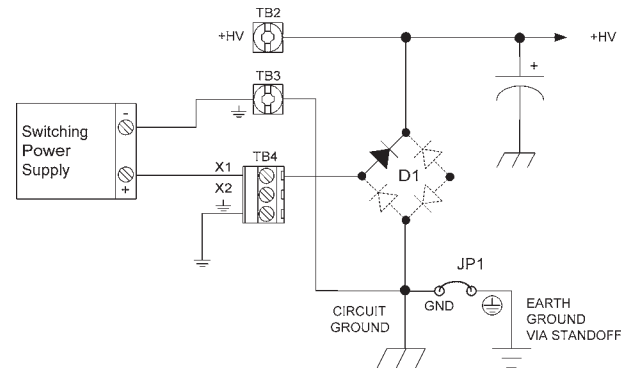

POWER SECTION SCHEMATIC

The following schematic shows the complete DC power section, along with component values.

Component Values & Ratings:

- C1~C4 = 12,000 uF, 100WVDC electrolytic capacitors
- D1 = 35A, 400V full-wave bridge rectifier
- TB2, TB3 = 15A, #6-32 screw terminal
- TB4 = Phoenix, MKDS 3/3 Euro terminal block
- Current ratings:
 - 24A (IEC / DIN VDE, nominal)
 - 15A (UL)
 - 10A (CSA)
- Wire gauges: AWG 24~12 (0,2~2,5 mm²)

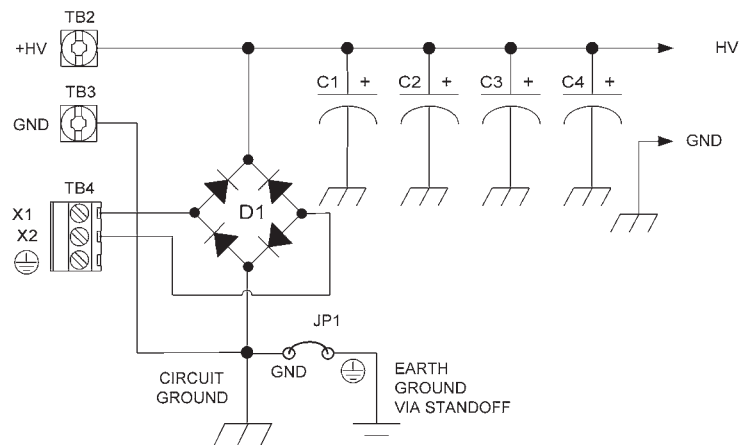

RECTIFIER/FILTER SECTION: GENERAL SPECIFICATIONS

FOR OPERATION FROM TRANSFORMER SECONDARIES (TB4-X1 & TB4-X2)

Input voltage	16 to 65	VAC from transformer-secondary (Note 1)(Note 2)
Input current (maximum)	10/15/24	Amps AC rms (CSA/UL/VDE)

FOR OPERATION FROM SWITCHING POWER SUPPLIES (TB4-X1 & TB3)

Input voltage	21 to 91	VDC, Isolated from mains, allowing ~1V for voltage-drop in rectifier (Note 1)
Input current	15	Amps DC

FOR OPERATION FROM UNREGULATED POWER SUPPLIES (TB2 & TB3)

Input voltage	20 to 90	VDC, Transformer-isolated (Note 1)
Input current	15	Amps DC

Notes:

1. Actual voltages used must consider which model *Accelus*[™] is to be mounted in the Development Kit. For ASC-055-18, Max VDC = 55V, for ASC-090-09, Max VDC = 90V.
2. Transformer input voltages shown do not take into consideration high and low line voltages, full-load to no-load changes, or ripple. Final voltage chosen for an application must consider these, as well as transformer tolerances.

CONNECTOR LAYOUT

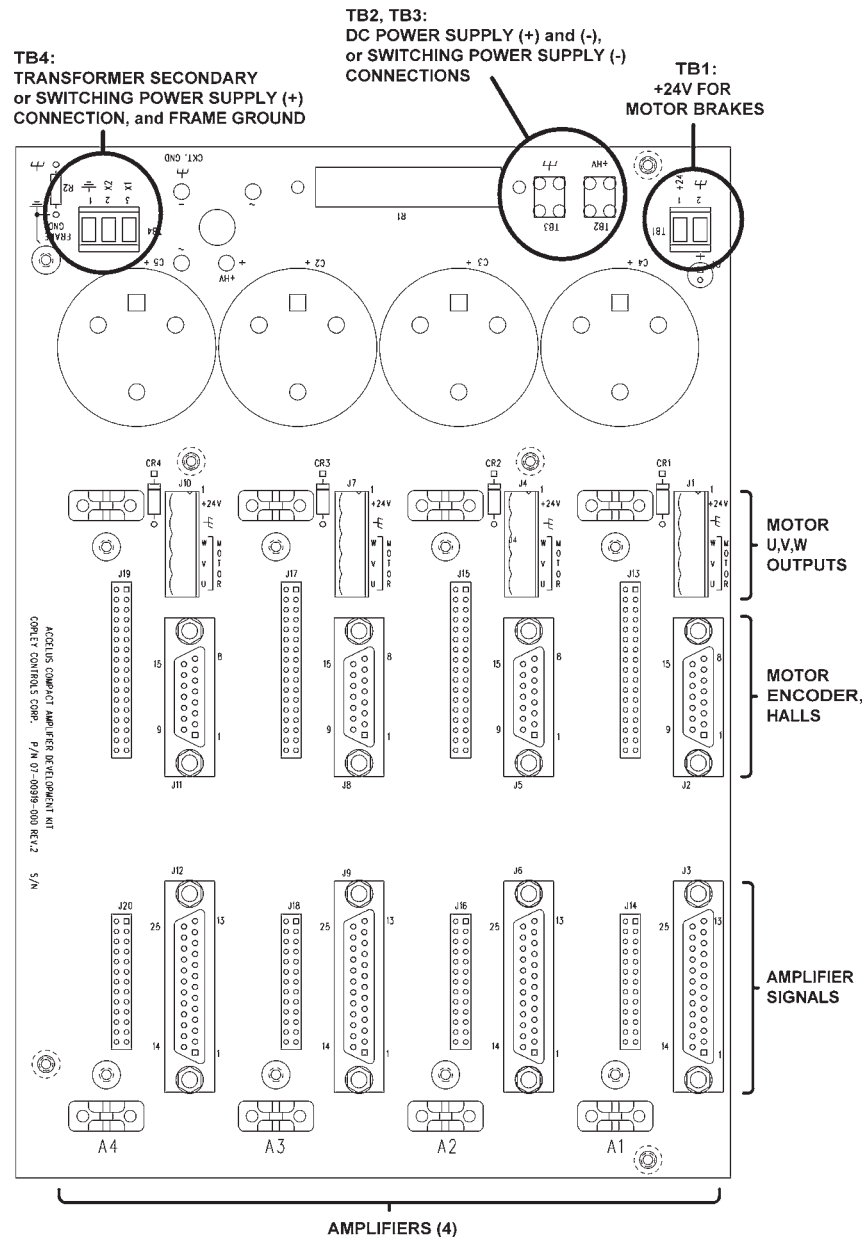

MATING (CABLE) CONNECTORS DEVELOPMENT KIT

Motor U,V,W Outputs: J1, J4, J7, J10:
Molex/Beau 5,08mm, Eurostyle®, 5-position
terminal block 860505-00, or equivalent.

Motor Encoder & Halls: J2, J5, J8, J11:
Sub-D, 15-position, male.

Amplifier Signals: J3, J6, J9, J12:
Sub-D, 25-position, male.

Note: Connector Kit #84-00065-000 contains one each of the above
listed connectors.

CONNECTIONS

1. J1, J2, & J3 are designators for amplifier A1.

For amplifiers A2, A3, & A4, the designations change, but the functions and connections remain the same.

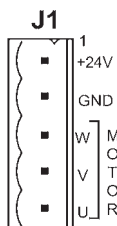

PIN	J1 SIGNAL
1	+24V to Brake
2	Ground
3	Motor W Output
4	Motor V Output
5	Motor U Output

J2 SIGNAL	J2
Encoder /A	15
Encoder /B	14
Encoder /X	13
Ground	12
+5V @ 200 mA	11
Ground	10
Motor Temp Sensor	9

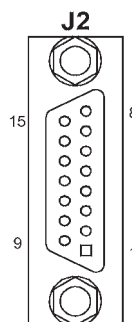

PIN	J2 SIGNAL
8	Encoder A
7	Encoder B
6	Encoder X
5	Hall Gnd
4	Hall W
3	Hall V
2	Hall U
1	Chassis Ground

J3 SIGNAL	PIN
RS-232 RxD Input	25
RS-232 TxD Output	24
+5V @ 200 mA	23
Ground	22
Encoder /A Output	21
Encoder /B Output	20
Encoder /X Output	19
Negative Enable Input	18
Positive Enable Input	17
Ground	16
Ground	15
±10V Ref(-) Input	14

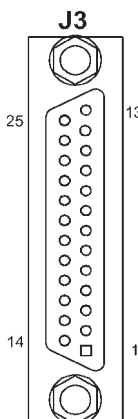

PIN	J3 SIGNAL
13	Ground
12	Ground
11	Motor Brake Output
10	Ground
9	Encoder A Output
8	Encoder B Output
7	Encoder X Output
6	Fault Output
5	Amp Enable Input
4	PWM Direction Input
3	PWM Reference Input
2	±10V Ref(+) Input
1	Chassis Ground

NOTES

- The +5V @ 200 mA supply in the Accelus™ amplifier is connected to J2-11 and J3-23 of each amplifier position. The total current from J2-11 and J3-23 cannot exceed 200 mA.
The +5V outputs from each amplifier cannot be connected together for higher power output.

MECHANICAL OUTLINE

Dimensions in inches (mm)

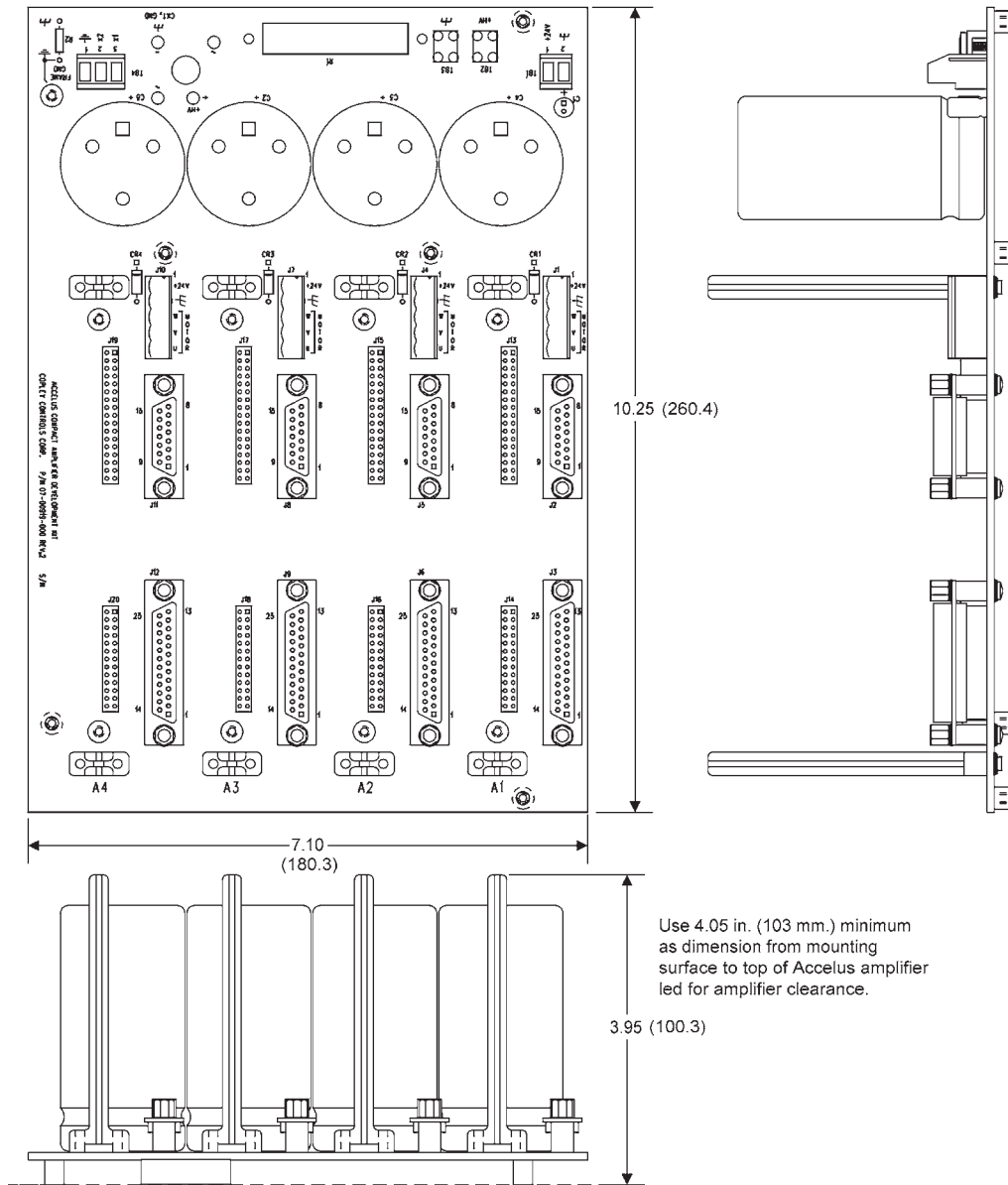

ORDERING GUIDE

PART NUMBER	DESCRIPTION
SDK-090-04	Development Kit (does not include connector kits, serial cable, or CD)
ASC-055-18	Accelus™ Card Amplifier 6/18A @ 55VDC
ASC-090-09	Accelus™ Card Amplifier 3/9A @ 90VDC
84-00065-000	Connector Kit (1 required per amplifier)
84-00064-000	Serial Cable Kit (1 per computer)
95-00203-000	CME 2™ CD (CME 2™, datasheet, manual, etc)

ORDERING INSTRUCTIONS

The Development Kit comprises the PC board assembly only. Amplifiers, connector kits, and CD must be ordered separately.

Example: For an SDK with two *Accelus™* amplifiers, order the following:

Qty	Item	Remarks
1	SDK-090-04	<i>Accelus™</i> Development Kit
2	ASC-055-18	<i>Accelus™</i> Card servoamplifier
2	84-00065-000	Connector Kits
1	84-00064-000	Serial Cable Kit
1	95-00203-000	CME 2™ CD

Version 2.01_mo 01/19/2009