

Bipolar Stepper Motor Power Stage with Plain Text Display



CCD+

Bipolar Stepper Motor Power Stage

with Plain Text Display

for Switching Cabinets

© 2008

All rights with:

Phytron-Elektronik GmbH

Industriestraße 12

82194 Gröbenzell, Deutschland

Tel.: +49(0)8142/503-0

Fax: +49(0)8142/503-190

Every possible care has been taken to ensure the accuracy of this technical manual. All information contained in this manual is correct to the best of our knowledge and belief but cannot be guaranteed. Furthermore we reserve the right to make improvements and enhancements to the manual and / or the devices described herein without prior notification.

We appreciate suggestions and criticisms for further improvement.

Please send your comments to the following e-mail address: doku@phytron.de

You'll find the updated version of this manual on the website of www.phytron.de.

Contents

1	CCD+	4	7.2.3 Control Pulses	33
1.1	Short Overview	4	7.2.4 Direction	33
1.2	Extent of Supply	7	7.2.5 Boost	33
1.3	Operating Modes	8	7.2.6 Deactivation	34
1.3.1	Operating Mode ‚Menu-Driven‘	8	7.2.7 Deselect	34
1.3.2	Operating Mode ‚ServiceBus‘	8	7.2.8 Reset	34
1.3.3	Operating Mode ‚Bus Mode Exclusive‘	8	7.3 Outputs	35
2	Technical Data Table	9	7.3.1 Ready	35
3	To Consider Before Installation	13	7.3.2 Error	35
3.1	Qualified Personnel	13	8 The Menu	37
3.2	Safety Instructions	13	8.1 Menu Function Test	38
3.3	Protective Measure Options	15	8.2 Main Menu	38
4	Mounting	17	8.3 Setup	39
4.1	Mounting Instructions	17	8.3.1 Menu Items in the Setup Menu	39
4.2	Temperature and Cooling Air Flow	19	8.3.2 Password Protection	41
4.3	Mounting an External Fan	20	8.4 Test	42
5	Power Supply	21	8.5 Error Messages	43
5.1	Connector „SUPPLY“	21	8.6 Trouble-Shooting	44
5.2	Accessories: Mains Transformer	21	9 ServiceBus Connection	45
5.3	Accessories: PS Power Supply Unit	22	9.1 ServiceBus Interface	45
5.4	DC Power Supply	23	9.2 USB Driver Installation	46
5.5	AC Power Supply	24	Appendix A: Technical Details	47
5.6	Current Setting	25	A1 Full Step / Half Step / Ministep	47
6	Motor connection	26	A2 Boost	50
6.1	Motor Connector	26	A3 Self-Adapting OVERDRIVE	51
6.2	Wiring Schemes	27	A4 Current Delay Time	52
6.3	Motor Cables	28	Appendix B	53
6.4	Shielding	29	B1 Warranty	53
7	Input and Output Connectors	30	B2 Trade Marks	53
7.1	Signal Connector	30	B3 ESD-Protective Measures	53
7.2	Inputs	31	Appendix C: Declarations of Conformity	54
7.2.1	Push-Pull- or Open Collector-Controlling	32	Index	56
7.2.2	Logic-Level 24 V or 5 V	32		

Manual CCD+

1 CCD+

In this chapter you'll find a brief description of the power stage CCD+ with scopes of delivery and operation modes.

1.1 Short Overview

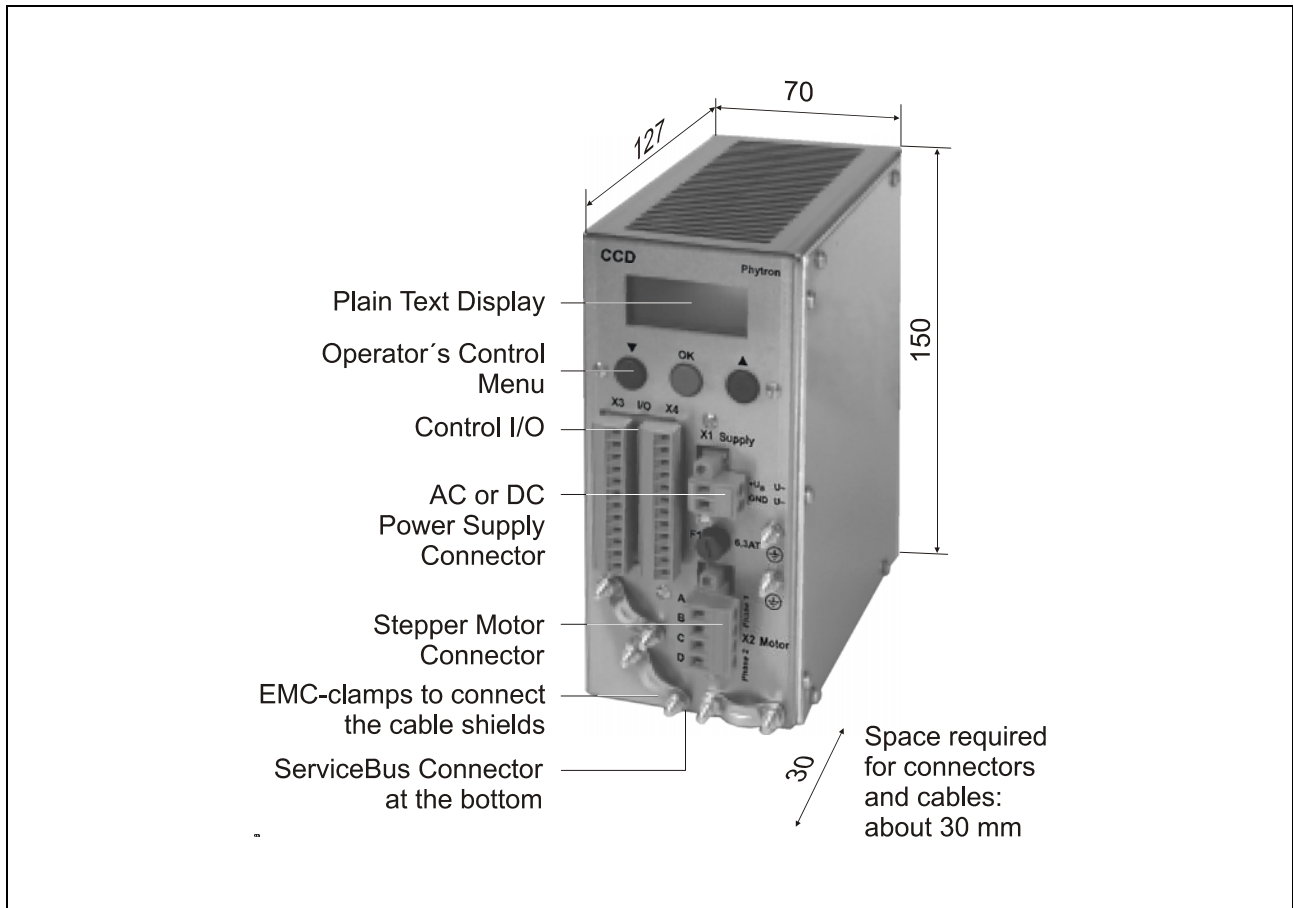

Fig. 1: Operator's control and Dimensions (mm)

Ministep power stage for 2 phase stepper motors with ServiceBus

The power stages type CCD+ use Phytron's welltried technology, now with enhanced 4 quadrant chopper type current control.

Phytron power stages with the addendum + are particularly service friendly by **ServiceBus**, which enables configuring, operating and monitoring the power stage via PC. For easy use of all setting options, the free ServiceBus-Comm[®] software for Windows[®] is included in delivery.

The operation parameter – run- and stop current, step resolution, preferential direction and current delay time, etc. – can be set either menu-driven or via ServiceBus.

The following step resolutions are selectable: full step, half step, 1/2.5, 1/4, 1/5, 1/8, 1/10, 1/16 and 1/20 step.

With the automatic overdrive function, a dynamic boost function, the CCD⁺ offers a self-adapting and therefore motor independent compensation of the torque decrease for higher frequencies.

Motorcurrents from 0.14 to 9 A_{Peak}

Run, stop and boost currents can be individually programmed in the set-up menu.

Supply voltage AC or DC

Rectifier, load capacitor and supply circuit for motor and logic voltage are included. A DC voltage with 24 to 70 VDC or a AC voltage with 17 to 50 VAC can be connected to the supply voltage connector.

Inputs

Controlling via RS 422 push-pull driver ensures high immunity against disturbances. Open-Collector controlling is also possible.

Plain text display 2 x 8 characters



Fig. 2: Plain text display with menu control buttons

- Menu-driven setup of current values, ministep resolution and other parameters
- Display of actual parameters, test mode
- True phase current RMS measurement
- Display of currents, voltage and temperature
- Diagnostics: Short circuit, low voltage and overtemperature monitors

Manual CCD+

ServiceBus

ServiceBus has to offer several opportunities:

- Power stage parameter programming:
Run-, stop- and boost current, step resolution, preferential direction, current delay time,...
- Software configuration by USB connection,
opto-decoupled from the motor current power supply
- Parameterstore for permanent storage of user-defined adjustments in the EPROM of the power stage.
- Connection or disconnection of the function Overdrive

The Software ServiceBus-Comm[®] is able to program the power stage quick and easy (See Manual ServiceBus-Comm[®]).

Easy to mount and EMC compliant

- Top hat rail mounting or wall mounting in switching cabinets
- Easy installation by means of screw-type connectors
- Fully EMC compliant metal housing
- Integrated EMC filter for supply cable
- Prepared for mounting an external 24V fan

1.2 Extent of Supply

The CCD⁺ is available in the following options (#: Ident number):

- for rail mounting with mating connectors X1 to X4:
 #10010111 (input level 5 V)
 #10010112 (input level 24 V)
- for wall mounting with mating connector X1 to X4:
 #10010113 (input level 5 V)
 #10010114 (input level 24 V)

Accessories:

- CCD⁺ Manual
- Phytron CD with ServiceBus-Comm[®] software
- ServiceBus-Comm[®] manual
- ServiceBus instruction set manual

Supplementary parts are available:

- Fan Papst 614 / 24 V_{DC} #02005791
- Rail mounting kit #02005659
- USB-cable (connection A-B) 200 cm #10006881
- Power supply PS 5-48 (5 A, 48 V) for rail mounting #10006780
- Power supply PS 5-48 (5 A, 48 V) for rail mounting #10006148
- Power supply PS 10-24 (10 A, 24 V) for wall mounting #10006781
- Power supply PS 10-24 (10 A, 24 V) for rail mounting #10006578
- Mating connector set X1 to X4 #02005660:

Connector	Number of poles	Mating connector Phoenix	Identity number
X1	2	MSTB2,5/2-STF-5,08	#02005267
X2	4	IC 2,5/4-STF-5,08	#02005578
X3/X4	12	MC 1,5/12-ST-3,81	#02005576

1.3 Operating Modes

The CCD+ can be used in 3 operating modes:

1.3.1 Operating Mode ‚Menu-Driven‘

All operation parameters are menu-driven with the input keys in the SETUP-menu. In the process the function **S-BUS=DISABLED** is defined.

1.3.2 Operating Mode ‚ServiceBus‘

The **S-BUS=ENABLED** in the SETUP-menu activates the ServiceBus mode and all settings are made by ServiceBus. The parameter values are shown in the CCD+ display during the operation. It is not possible to change parameters with the input keys, acknowledged by **!S-BUS ENABLED** (see chap. 9).

1.3.3 Operating Mode ‚Bus Mode Exclusive‘

The ‚bus mode exclusive‘ ensures safe operation in ServiceBus mode. If the power stage is set to ‚Bus mode exclusive‘ in service bus mode by ServiceBus-Comm (instruction code ‚PX‘), all settings with the menu buttons are ignored.

Leaving the mode is only possible via ServiceBus by ‚PX‘ instruction code.

2 Technical Data Table

Technical Data																																					
Default values of parameters	<p>The power stages are set to the following values at delivery:</p> <table> <tr><td>Run current I-RUN</td><td>1 A</td></tr> <tr><td>Stop current I-STOP</td><td>0.5 A</td></tr> <tr><td>Boost current I-BOOST</td><td>1 A</td></tr> <tr><td>Preferential direction</td><td>CCW</td></tr> <tr><td>Current delay time I-DELAY</td><td>40 ms</td></tr> <tr><td>Step resolution MINISTEP</td><td>1/20</td></tr> <tr><td>Overdrive</td><td>OFF</td></tr> <tr><td>Display contrast LCDCTR</td><td>50</td></tr> <tr><td>No Temperature sensor TSENS</td><td>NONE</td></tr> <tr><td>Temperature limit 1 TLIM1</td><td>60 °C</td></tr> <tr><td>Temperature limit 2 TLIM2</td><td>80 °C</td></tr> <tr><td>Temperature limit 3 TLIM3</td><td>100 °C</td></tr> <tr><td>Degassing D-GAS</td><td>DISABLED</td></tr> <tr><td>No customer specific displays</td><td></td></tr> <tr><td>DISP-1</td><td>NONE</td></tr> <tr><td>DISP-2</td><td>NONE</td></tr> <tr><td>Password protection off</td><td>Anzeige: OK</td></tr> <tr><td>S-BUS</td><td>DISABLED</td></tr> </table>	Run current I-RUN	1 A	Stop current I-STOP	0.5 A	Boost current I-BOOST	1 A	Preferential direction	CCW	Current delay time I-DELAY	40 ms	Step resolution MINISTEP	1/20	Overdrive	OFF	Display contrast LCDCTR	50	No Temperature sensor TSENS	NONE	Temperature limit 1 TLIM1	60 °C	Temperature limit 2 TLIM2	80 °C	Temperature limit 3 TLIM3	100 °C	Degassing D-GAS	DISABLED	No customer specific displays		DISP-1	NONE	DISP-2	NONE	Password protection off	Anzeige: OK	S-BUS	DISABLED
Run current I-RUN	1 A																																				
Stop current I-STOP	0.5 A																																				
Boost current I-BOOST	1 A																																				
Preferential direction	CCW																																				
Current delay time I-DELAY	40 ms																																				
Step resolution MINISTEP	1/20																																				
Overdrive	OFF																																				
Display contrast LCDCTR	50																																				
No Temperature sensor TSENS	NONE																																				
Temperature limit 1 TLIM1	60 °C																																				
Temperature limit 2 TLIM2	80 °C																																				
Temperature limit 3 TLIM3	100 °C																																				
Degassing D-GAS	DISABLED																																				
No customer specific displays																																					
DISP-1	NONE																																				
DISP-2	NONE																																				
Password protection off	Anzeige: OK																																				
S-BUS	DISABLED																																				
Stepper motor	<p>2-phase-stepper motors in 4-, 6- or 8-leed-design with 0.5 to 9 A_{Peak} phase current</p> <p>Winding resistance < 10 Ohm</p> <p>Winding inductivity of a motor phase 0.5 to 10 mH</p>																																				
Step resolution	<p>Step resolution is adjustable by Setup-menu or ServiceBus:</p> <p>Full step, half step, 1/2,5 step, 1/4 step, 1/5 step, 1/8 step, 1/10 step or 1/20 step.</p>																																				
Phase currents	<p>Run current, stop current and boost current are set independently in 0.1 A steps in Setup menu by ServiceBus.</p> <p>Programmable values: 0.1 to 6.3 A_{eff}</p> <p>Peak current 0.14 to 9 A_{Peak}</p> <p>Set phase currents appropriate to rated current of the motor winding! Settings on device delivery: 1 A run current, 0.5 A stop current and 1 A boost current</p>																																				
Permissible motor cable length	<p>Depending on current setting and winding resistance, see chap.5.6</p>																																				

Manual CCD+

Technical Data	
Cable cross-section motor cable	Recommended are at least 1 mm ² , depended on maximum current of the motors and the motor cable length it ca also be used a smaller cable cross section.
Supply voltage	17 to 50 V _{AC} or 24 to 70 V _{DC} Nominal current: 6 A _{eff} temporary: 7 A _{eff}
Transformer supply voltage	Base insulation for mains supply circuits with a rating of 250 V _{AC} acc. to EN 50178
Error message Undervoltage	Supply voltage < 17 V _{DC}
Fuse F1	6.3 A delayed with high switching capacity
Suitability of the device	The device is used for mounting in the installation cabinet. Depended on the designated power supply and the applied rules other sites are permissible.
Mounting	Rail mounting or wall mounting depended on the mounting kit.
Minimum technical spaces	Minimum technical spaces with nearby devices: 30 mm Minimal free space over and under the CCD ⁺ : 100 mm Required space for connectors and cables: ca. 30 mm on the front side of the CCD ⁺
Permissible surrounding temperature	Operation: 5 to 40 °C Storage: -25 to +55 °C Transport: -25 to +50 °C
Ventilation	Operation without fan: up to 40 °C ambient temperature with a phase current up to 4 A The CCD ⁺ can be operated up to 50 °C ambient temperature with an external fan (Papst 614, 24 V _{DC}), also with full current and 100% duty cycle, see chap. 4.2.
Opportunities of mounting a fan	4 x fastening screw thread M3 (Raster 50 x 50 mm) for mounting a 24-V fan at the bottom of the housing. Warning: The mounting screws may penetrate maximum 3 mm into the device!
Weight	1.1 kg

Technical Data			
Connector at power supply cable	Phoenix Combicon connector, type MSTB 2,5/2-STF-5,08		
Connector at motor cable	Phoenix Combicon connector, type C 2,5/4-STF-5,08		
Connector at I/O-cable	2 x 12-pole Phoenix Mini Combicon connector, type MC 1,5/12-ST-3,81		
Connector at ServiceBus-cable	4-pole ServiceBus connector, type (A) DIN IEC 61076-3-107 (to PC) 4-pole ServiceBus connector, type (B) DIN IEC 61076-3-108 (to CCD ⁺)		
Wiring I/O's	Double or reinforced insulation for 160 V _{DC} against supply and motor voltage as well as against temperature sensor wires.		
Inputs	Inputs are opto-decoupled. Triggering by push-pull-drivers or open collector Input level 5 V or 24 V (depends on CCD ⁺ version)		
	Signal level	5 V 24 V	
	High	3 – 5.5 V 20 – 30 V	
	Low	< 0.4 V < 3 V	
	Necessary driver current	max. 10 mA (at 3 V)	max. 10 mA (at 20 V)
		max. 30 mA (at 5.5V)	max. 20 mA (at 30 V)
Control pulses	Maximum step frequency: 250 kHz Minimum pulse width: 2µs The step is done with the falling flank of the control pulse.		
Motor direction	When the optocoupler is energized, the motor rotates in the reverse direction. The direction of rotation signal should not be changed at least 1µsec before the rising flank and after the falling flank of the control pulse!		
Boost	If the optocoupler is energized, the CCD ⁺ switches the current to the selected value for the Boost current.		
Deactivation	If the optocoupler is energized, the motor current is deactivated.		

Manual CCD+

Technical Data	
Deselect	Pulse inhibit, when current flows through the optocoupler. If the input is not connected, the power stage is ready for work.
Reset	A reset causes resetting of all error messages. Waiting time after cut off the Reset signal: about 500 msec
Outputs	Opto-decoupled, type Open-Collector Darlington $I_{\max} = 20 \text{ mA}$, $U_{\max} = 30 \text{ V}$, $U_{CE \text{ sat}} \text{ bei } 20 \text{ mA} < 1 \text{ V}$, $P_{\text{total}} = 300 \text{ mW}$
Ready	The CCD+ is ready to operate, if the output „Ready“ is closed (current is flowing). The input "Deactivation" must not be energized.
Error	The common error output opens in case of the following error signals: short circuit, undervoltage, overtemperature. To avoid damages, the drive is deactivated at the same time.

3 To Consider Before Installation



Read this manual very carefully before installing and operating the CCD⁺.

Observe the safety instructions in the following chapter!

3.1 Qualified Personnel

Design, installation and operation of systems using the CCD⁺ may only be performed by qualified and trained personnel.

These persons should be able to recognize and handle risks emerging from electrical, mechanical or electronical system parts.



WARNING !

By persons without the proper training and qualification damages to devices and persons might result!

3.2 Safety Instructions



1. Please observe the earthing instructions chap. 6.4!

2. In case of supply voltages > 24 V:

The CCD must only be operated if CCD⁺ housing and motor housing are connected to protective earth.

3. The connectors SUPPLY and MOTOR should be locked with the fixing screws.



4. **Up to 3 minutes after turning off the supply voltage, dangerous voltages may still exist within the device.**

5. **Be careful handling the connectors „Motor“ at the CCD⁺ and any motor cable coupling.**

As long as the CCD⁺ is connected to supply voltage, a hazardous voltage level is present at motor connector and motor cable, even if the motor is not wired.

6. **Up to 3 minutes after turning off the supply voltage, dangerous voltages may still exist at the CCD⁺ connectors.**

7. Always switch off the supply voltage if you connect or disconnect any wires or connectors at the CCD+.

Most important:

Do not unplug the motor connector while powered.

Danger of electric arcing.

8. Voltages connected to the signal inputs and outputs (connectors X3, X4) should be safely separated from mains. The maximum voltage against protective earth must not exceed $60 V_{DC}$ or $25 V_{AC}$.
9. Clearing the inputs DEACTIVATE or deselection with the input DESELECT or RESET is no sure separation in the emergency case.

The voltage supply has to be interrupted for switching off the drive safely



10. The surface of the CCD+ may reach temperatures of more than 70 °C .
Danger of injury if touching the surface!

3.3 Protective Measure Options

The control unit must be operated by the protective measure PELV acc. to VDE 0100. Board and motor housing have to be grounded and/or connected to 0 V.

Various options are possible to achieve the protective measure PELV:

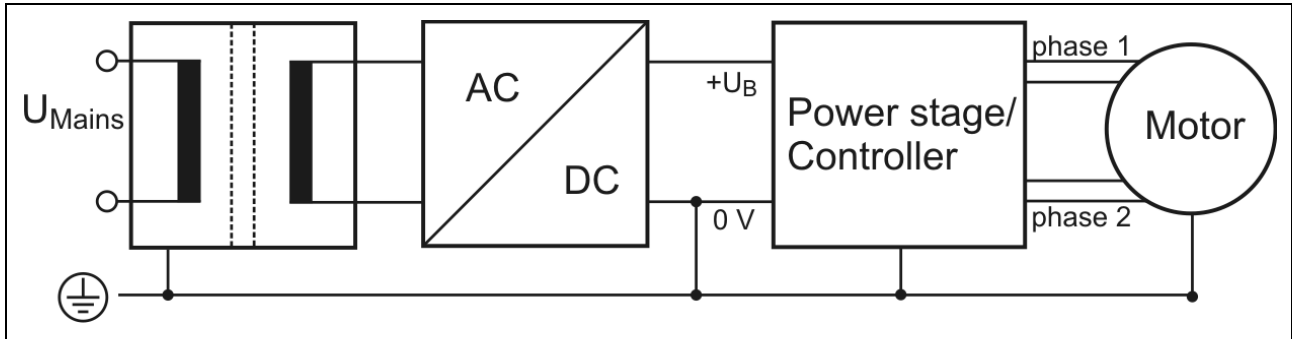

Fig. 3: PELV – Grounding: total

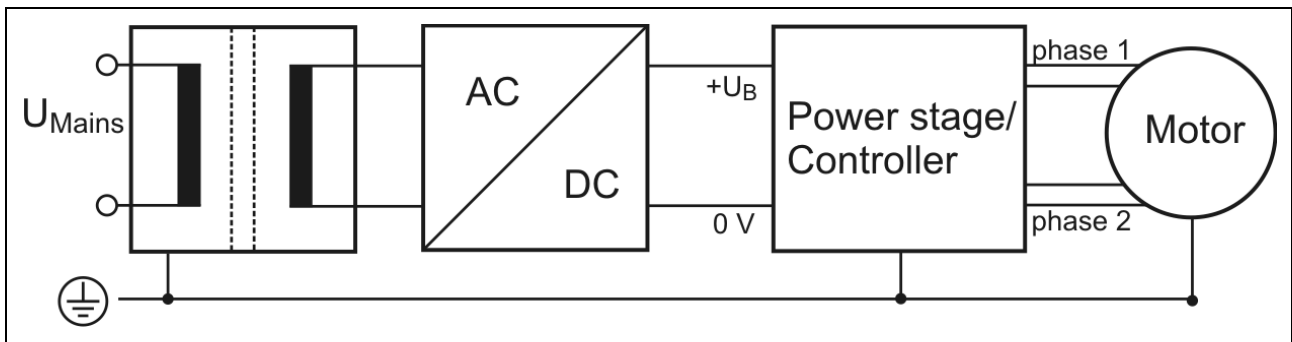

Fig. 4: PELV – Grounding: Controller and Motor.
The secondary winding of the transformer (SELV supply) must not be grounded because the equipment is grounded

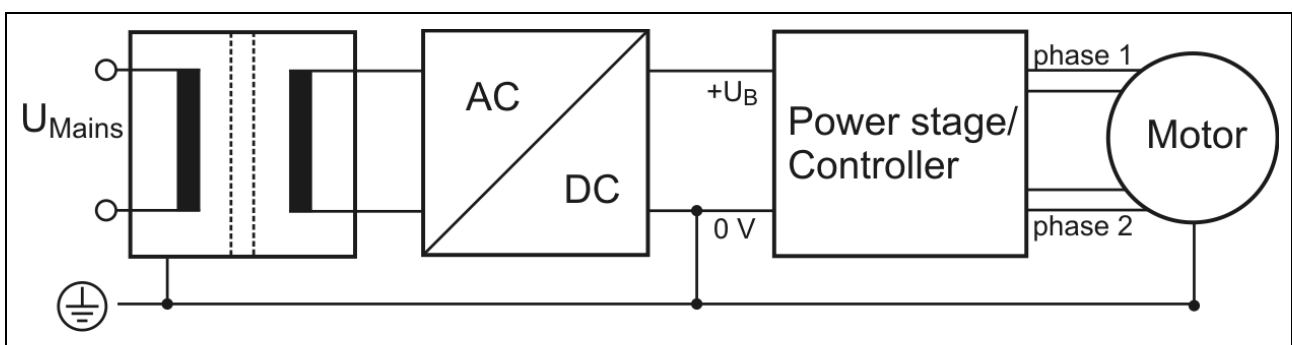

Fig. 5: PELV – Grounding: 0 V and Motor

Manual CCD+

If there is no PE clamp on the motor, the 0 V wire **must** be grounded to complete the protective measure PELV (Fig. 6 and Fig.7):

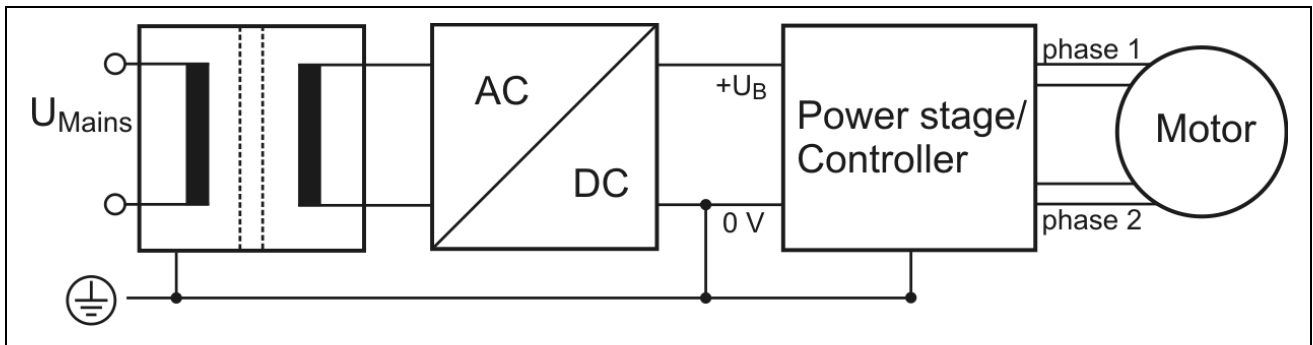

Fig. 6: PELV – Grounding: 0 V and Controller

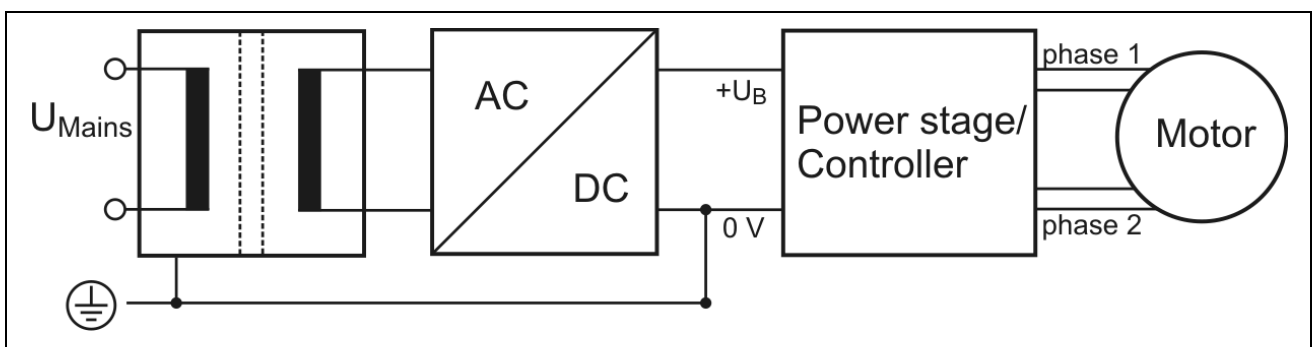

Fig. 7: PELV – Grounding: 0 V



Protective measure PELV for application of the $+U_B$ should not exceed $70 V_{DC}$ or $50 V_{AC}$ at dry environment (environmental conditions 3 acc. to IEC 61201).

The supply transformer must be constructed with reinforced or double insulation between supply and secondary winding (acc. to EN 61558).

Only use motors which are checked acc. to EN 60034-1 (500 V_{AC} /1 minute).

4 Mounting

In this chapter you will find all informations about mounting the CCD⁺ inside a switching cabinet and mounting an external fan.

4.1 Mounting Instructions

- The CCD⁺ has been designed to be mounted inside a switching cabinet. Depending on operating voltage and applicable standards, other environments can also be permissible.
- The CCD⁺ should be vertically mounted.
- Mount the CCD⁺ device at a plane surface with appropriate load capacity (device weight is about 1.1 kg).

Use the mounting kit delivered with the device for rail mounting or wall mounting.

You may also use the mounting threads in the device's back plate for individual mounting solutions.



- The mounting screws used must intrude not more than 3 mm into the device's inner parts!

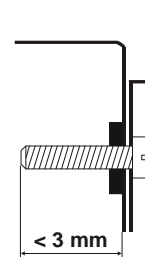

- Recommended free space below and above the device: 100 mm. Keep the air slots free to allow a convective air exchange!
- Recommended free space to other devices besides the CCD⁺: 30 mm
- Recommended free space for cables and connectors before the front plate of the device: 30 mm.
- The device has to be mounted and operated at a place free of shocks and vibrations

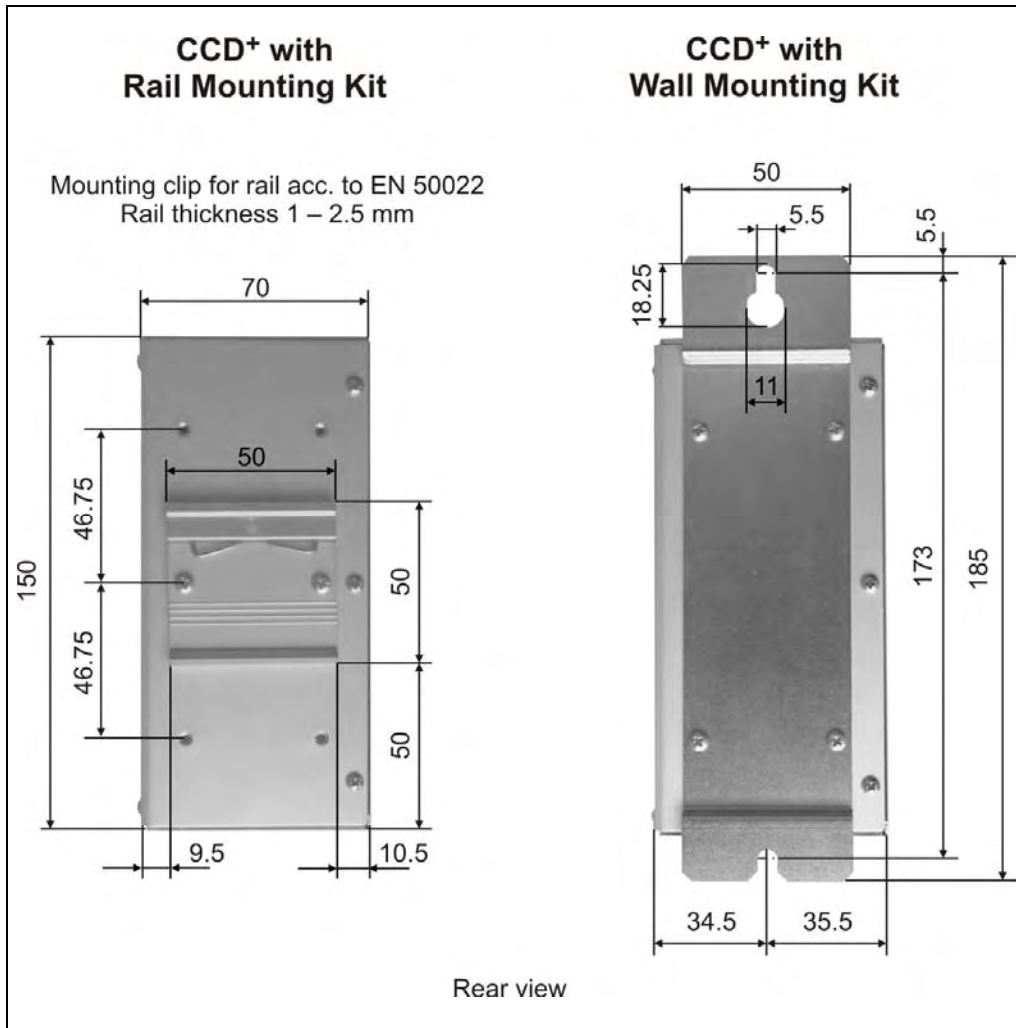

Fig. 8: Mounting kits

4.2 Temperature and Cooling Air Flow

If mounting several CCD⁺ devices one upon another be sure that the requirements for cooling air are met also at the topmost air inlet!

- The heat production in the CCD⁺ devices proportionally depends on the motor current used. It can be maximum 150 W.
- The maximum permissible ambient temperature depends on the phase current and cooling air flow follows from the de-rating diagram (see below).
- The curve without fan is valid for 100% duty cycle.
- The CCD⁺ can be operated without an external fan with motor currents up to about 3 Amps, even at an ambient temperature of 50 °C.
- Using an external fan (Papst type 614 operated at 24 V_{DC}) the CCD⁺ device can be operated with maximum phase current and 100% duty cycle even at an ambient temperature as high as 50 °C.

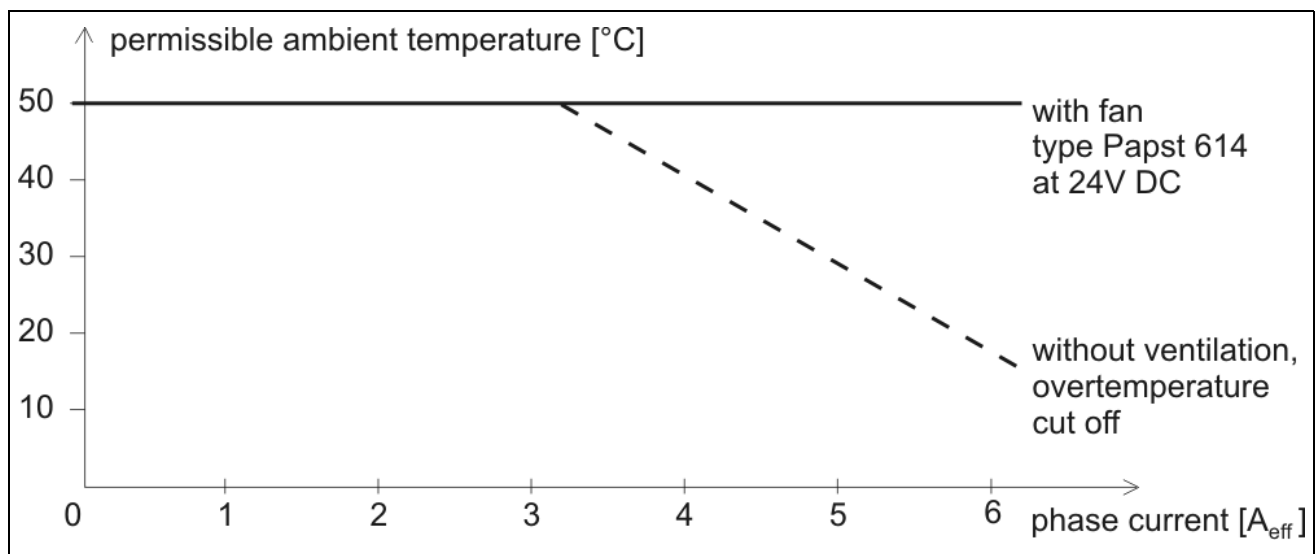

Fig. 9: De-Rating

4.3 Mounting an External Fan

- The CCD+ housing is prepared for the easy mounting of an external fan.

Type: Papst 614

Air Flow: 40 m³/h

Power supply: 24 V_{DC}

- Mounting:

For full cooling power dismount the air slot segment in the bottom plate of the CCD+ housing. Carefully cut the four metal bridges.

Metal scoops must not get into the CCD+'s housing!

Mount the fan with four cylinder head screws M3*6.

If you want to insert the screws into the holes on both sides of the fan's housing, four type M3*30 cylinder head screws should be used.

The preferred air flow direction is from bottom to top. Check the mounting direction of the fan for this, the arrow on the fan's housing shows the air direction!



- **The mounting screws must not intrude more than 3 mm into the CCD+ housing! Risk of damage or injury!**

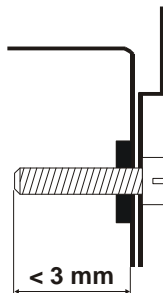

5 Power Supply

The following chapters give information about the power supply of the CCD⁺ with DC or AC and about current set up. The supply voltage has to be connected to the connector X1 „Supply“.

5.1 Connector „SUPPLY“

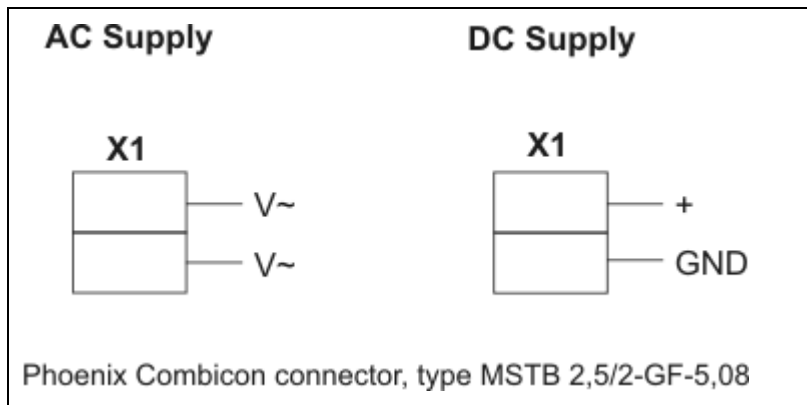

Permissible power supply range:

17 to 50 V_{AC}
or
24 to 70 V_{DC}

Fig. 10: Connecting the power supply voltage

The protective earth connection of the power supply has to be mounted to the bolts nearby the SUPPLY connector. Also see chap.3.3.

We recommend to fix the supply cable with the strain relief clamps.

5.2 Accessories: Mains Transformer

The CCD⁺ can be connected with a transformer directly to the mains circuit.

Phytron's toroidal core transformer for 115 V_{AC} or 230 V_{AC} supply voltage delivers an output voltage 50 V_{AC} / 4.5 A.

The transformer has 230 VA permissible power dissipation and a thermo protection element for 130 °C.

-  **The supply transformer must be constructed with reinforced or double insulation between supply and secondary winding**
- The secondary winding of the transformer (SELV supply) must not be grounded.

5.3 Accessories: PS Power Supply Unit

The power supply unit PS 5-48 / PS 10-24 provide 5 A/48 V_{DC} or 10 A/24 V_{DC} for the supply of the CCD⁺. Depended on the load, the power supply unit is able to provide several devices.

PS 5-48 / PS 10-24 are connected straight to the power supply voltage 230 or 115 V_{AC}.

The power input is protected internal, the output is save against continuous short-circuit. Save working is possible because of protective over temperature and over voltage and power failure bridging.

The power supply units PS 5-48 or PS10-24 can be mounted by rail mounting in the switching cabinets.

See Manual PS 5-48 / PS 10-24.

5.4 DC Power Supply

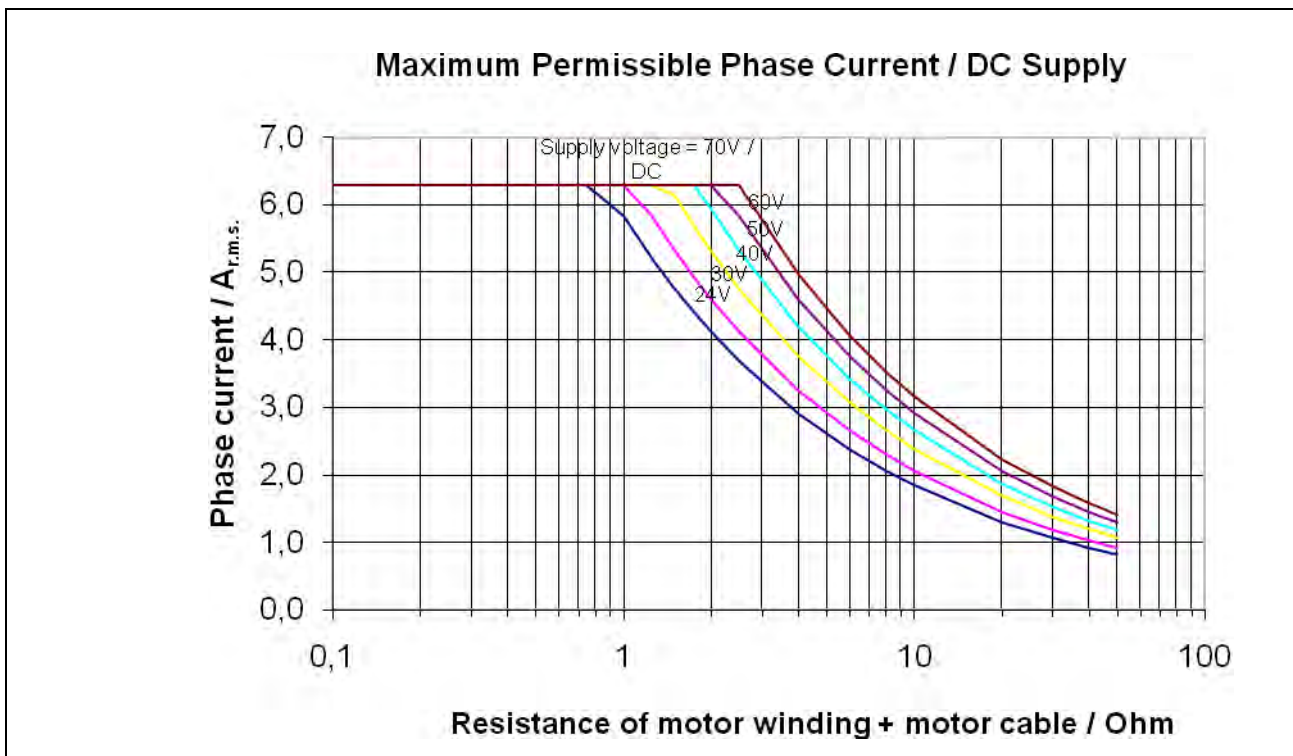

Fig. 11: DC Supply voltage mode

Acceptable supply voltage range if operated with smoothed direct current supply:
 24 V_{DC} to 70 V_{DC}.

The supply voltage must not drop under 17 V, not even for a very short period (> 1 msec).
 The CCD⁺ would recognize this as a low voltage error condition and switch off.

Power supply design considerations: The following formula allows to estimate the current required, if the CCD⁺ device is supplied with rectified and smoothed DC current:

$$I_{Supply\ DC} = \frac{2,7 * R_{ges} * I_{ph}^2}{U_{Supply\ DC}} + 3,3A$$

where:

I_{ph}: Phase current as set in the CCD⁺ menu.

R_{ges}: Total resistance of motor winding and motor cable of one phase.

I_{Supply DC}: Supply current, effective value if power supply delivers direct current.

U_{Supply DC}: Effective value of the supply voltage if direct current supply is used.

Operating time = 100%

5.5 AC Power Supply

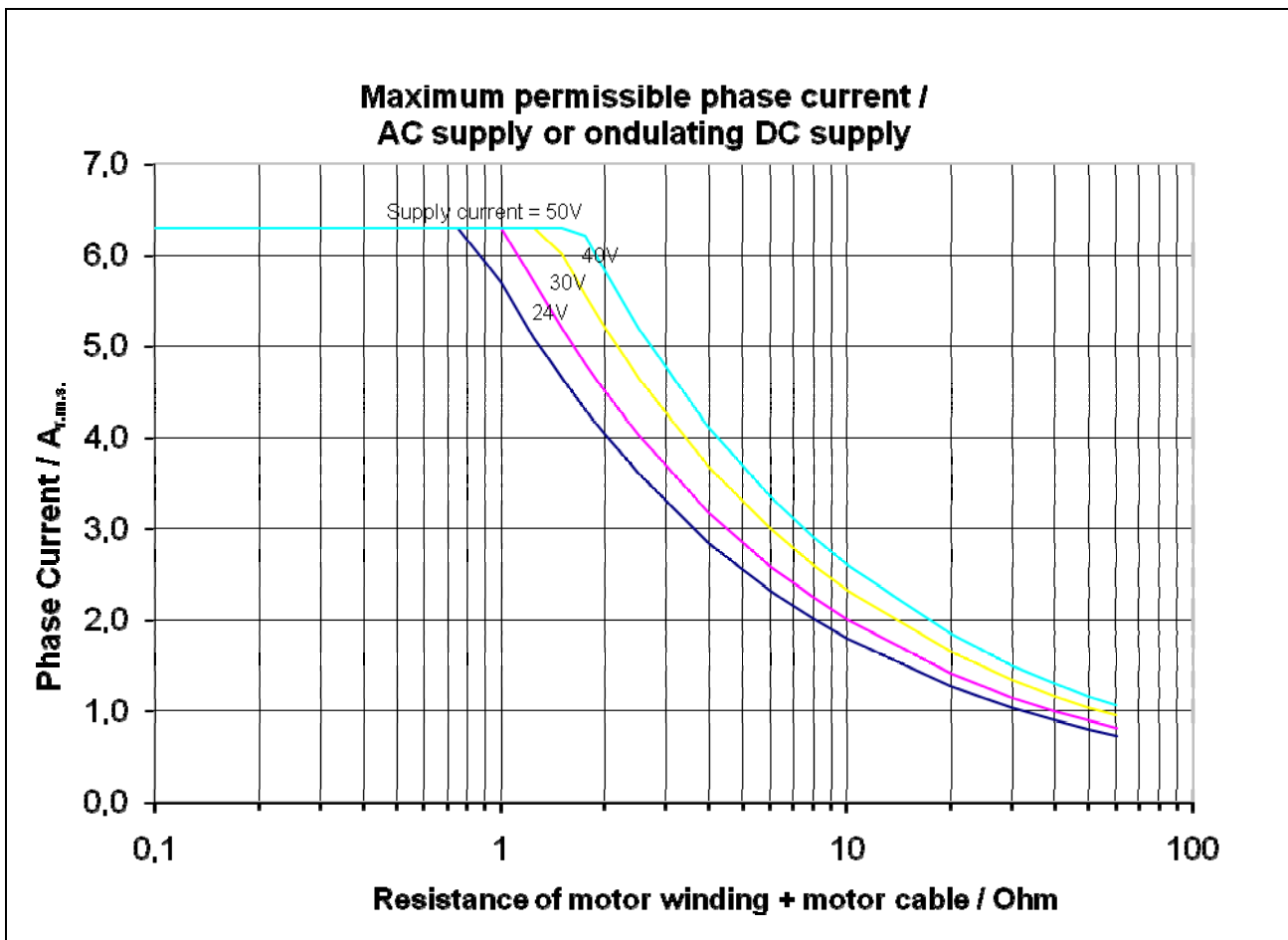

Fig. 12: AC supply voltage

The acceptable supply voltage range is: 24 V_{AC} to 57 V_{AC} (RMS value).

The peak voltage of the AC power supply must not be lower than 34 V (= 24 V_{AC} * √2), even with full load and voltage deviations of -10%.

Power supply design considerations: The following formula can be used to estimate the effective alternating current which has to be available at the connector SUPPLY, even if the system is operated with 100% duty cycle:

$$I_{Supply DC} = \frac{2,7 * R_{ges} * I_{ph}^2}{U_{Supply AC}} + 4,7 A$$

where:

I_{ph}: Phase current as set up in the CCD menu

R_{ges}: Total resistance of motor phase and cabling

I_{Supply AC}: Effective value of the supply current if AC supply is used

U_{Supply AC}: Effective value of the supply voltage if AC supply is used

Operating time = 100%

5.6 Current Setting

Run current, stop current and boost current can be set individually in steps of 0.1 A.



Set up currents correctly fitting to the motor winding's design current !

Current range:	0.1 to 6.3 A _{r.m.s.}
Peak current resulting:	0.14 to 9 A _{Peak}
Supply current:	6 A _{r.m.s.}
Sort time limit:	7 A _{r.m.s.}

Factory default settings of the CCD⁺:

Run current:	1 A
Stop current:	0.5 A
Boost current:	1 A

The **maximum current consumption** depends on the supply voltage, the phase current selected and the ohmic resistance of motor winding and motor cable.

The mean current value at the supply inlet, evaluated over a period of 30 sec, must not exceed 6.3 A.

Note: The above phase current diagrams (Fig. 11 and Fig. 12) are based on the following thermal assumptions:

- maximum duty cycle DC = 70%
- for the other 30%: stop current ≤ 50% of the maximum permissible run current
- maximum cycle time 30 sec

If the maximum current is switched on during more than 70% of the cycle time, or if the cycle time is longer than 30 seconds, the current has to be reduced by a factor of 0.8.

Example:

A stepper motor with 6.5 A nominal phase current is intended to be used with 6.3 A phase current. The motor winding resistance is assumed to be 0.5 Ω, and the supply voltage to be 50 V_{AC}.

According to the above diagram the resistance of each phase (winding and cabling) must not exceed 1.3 Ω .

According to the above diagram the resistance of each phase (winding and cabling) must not exceed 1.3 Ω .

The cable resistance (forth and back summed up) must therefore be less than
 $1,3\Omega - 0,5\Omega = 0,8\Omega$

Assuming a cable cross section of 1mm² with a resistance per meter of 0.02 Ω/m the

maximum cable length in this case would be limited to $\frac{0,8 \Omega}{2 * 0,02 \Omega/m} = 20m$.

Manual CCD+

6 Motor connection

The following chapter gives a description of how to wire different types of 2-phase stepper motors in 4-, 6- or 8 lead wiring.

CCD+ stepper motor controllers may be connected to stepper motors with 0.5 to 9 A_{Peak} phase current.

The stepper motor winding resistance should be less than 10 ohm for full power.

The winding inductivity of one phase should be in the range of 0.5 to 10 mH.

Stepper motors with 8 leads can be connected with the windings wired in parallel (1) or serial (2).

For the 6-lead stepper motors, wiring scheme (3) with serial windings is recommended.

If wiring scheme (3) cannot be used because of the motor construction, the motor may be operated with only two of the four windings energized according to wiring scheme (4). Power stages are suitable to energize 2 phase stepper motors in 4-, 6-, or 8 lead wiring scheme.



5-lead stepper motors must **not** be connected to the CCD+.

Both 5-lead stepper motor and CCD+ might be damaged.



Control by means of the motor specification, whether the regulated current is allowed for the stepper motor.

6.1 Motor Connector

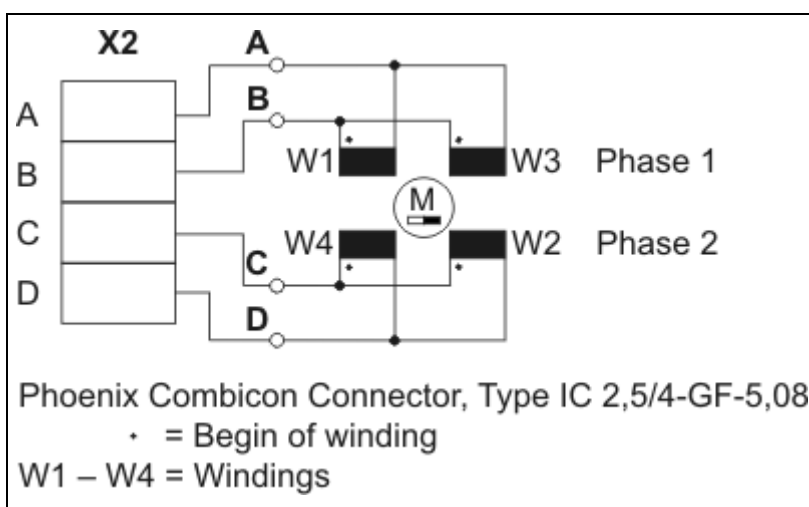

Fig. 13: Motor connector X2

6.2 Wiring Schemes

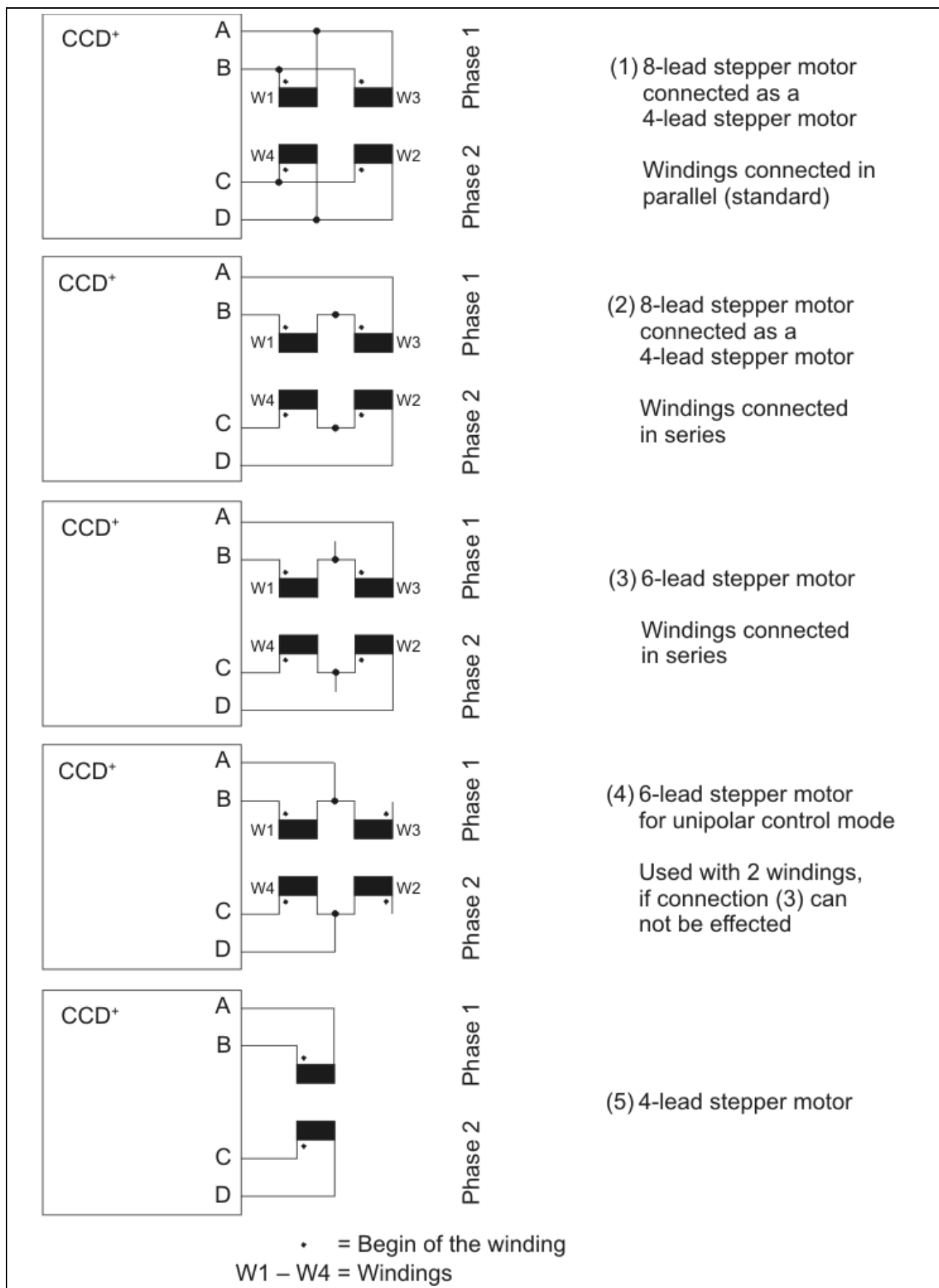

Fig. 14: Connection diagrams for 4-, 6- and 8-wire stepper motors

6.3 Motor Cables

The stepper motor must be connected with a 5-lead cable with shielding mesh. For optimum electromagnetic compatibility (EMC), the cable must not be interrupted by additional connectors or screw terminals.

Recommended cable cross section: 1 mm² for full power

Acceptable motor cable length: depending on current setting, motor resistance and cable cross section (chapter 5.6).

If there is a protective conductor clamp on the motor, it must be connected to the power stage. If there is no earthing screw on the motor, the “0V conductor” motor must be earthed. See chap. 3.3.

6.4 Shielding

To avoid disturbances affecting the wires and instruments installed close to the drive system, only shielded cables must be used.

Motor and power stage should be connected to ground by a central earthing tab.

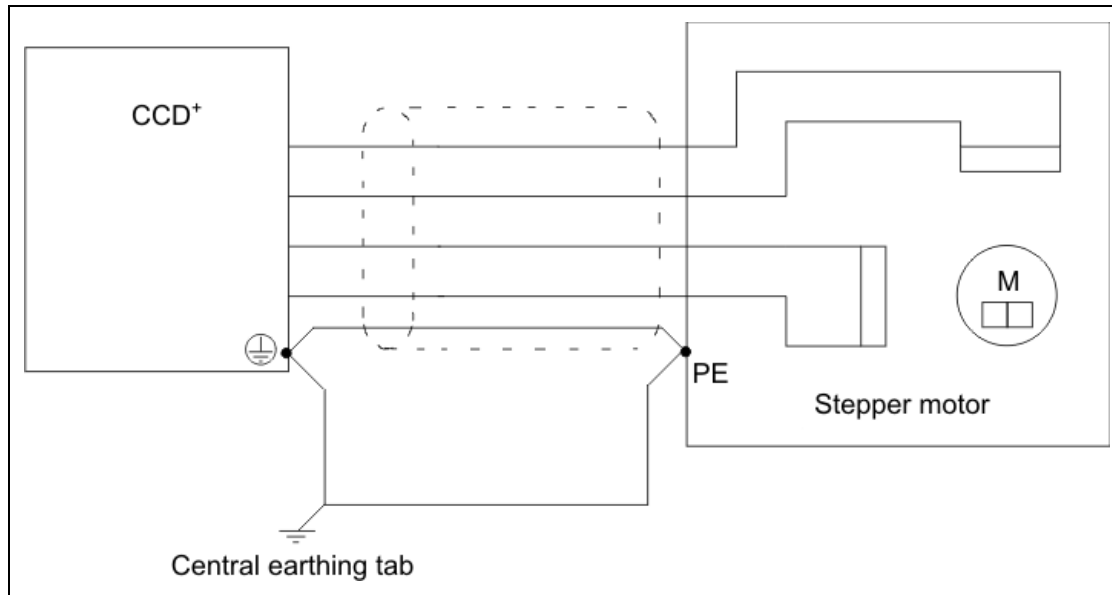

Fig. 15: Motor lead shielding and earthing



For best electromagnetic compatibility (EMC), you must connect the shielding mesh to the CCD⁺ housing. Use the cable clamps at the front side of the CCD⁺. Free cable ends must be as short as possible.

The shielding mesh must also be connected on a large surface to the motor housing. Use EMC-type conduit fittings. All parts of the motor must be conductively connected with each other.

In case of motors without adapted conduit fittings the cable shielding must be connected as near to the motor as possible and has to be applied to PE.

Important:

Motor leads not used should be insulated separately (important if using wiring scheme 3 or 4)!

If the motor is connected in the required way, the fault-free operation is assured according to EN 61000-6-1/2.

The manufacturer of the equipment/machine is responsible for the adherence to limit values, required by the EMC legislation.

7 Input and Output Connectors

The I/O connectors X3 and X4 are used to connect the CCD+ with digital process control signals and an auxiliary power supply.

Warning:

Please check the input level of the CCD – 5 V or 24 V – corresponding to the controller!

7.1 Signal Connector

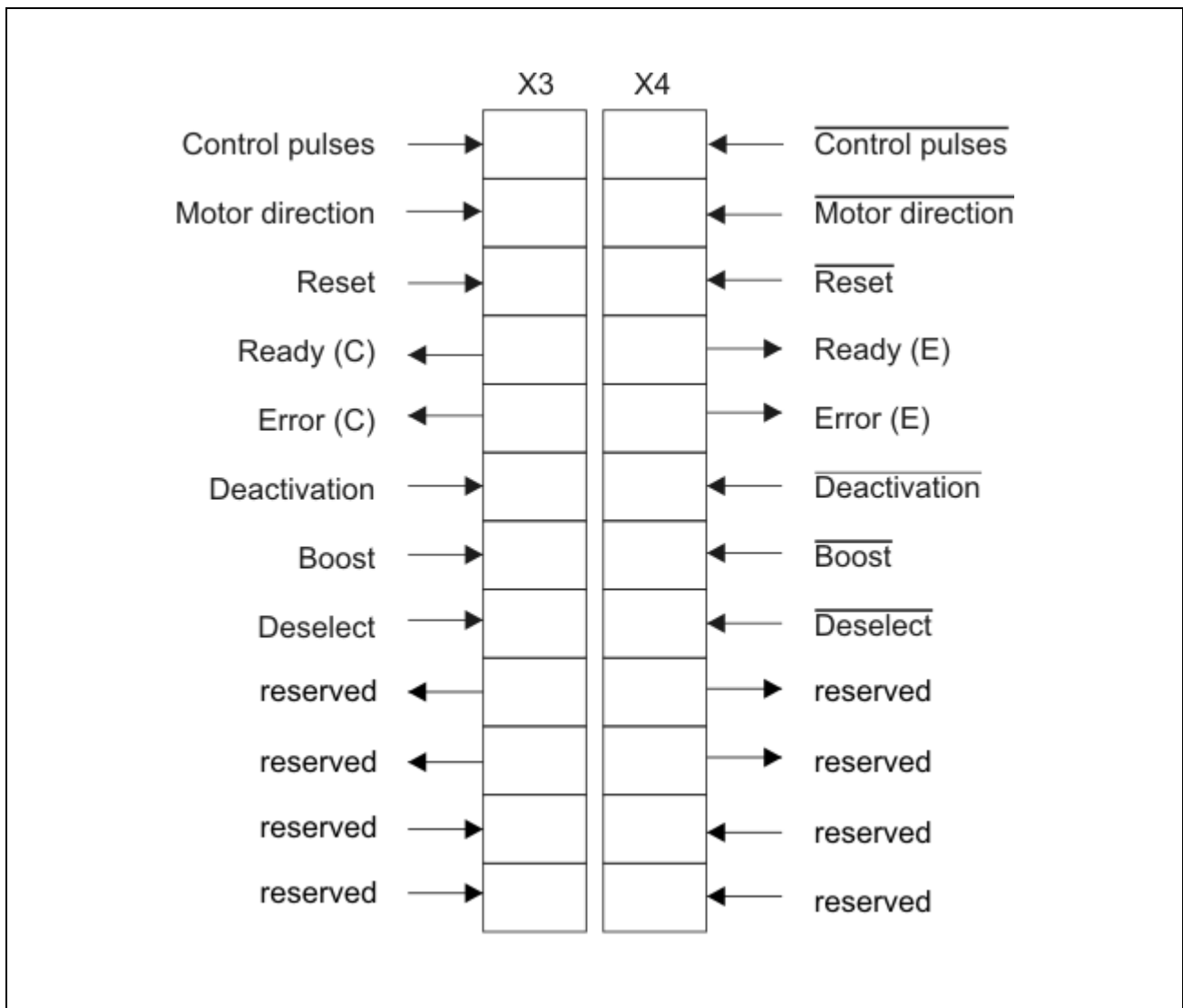

Fig. 16: I/O Signal Connectors

7.2 Inputs

The control inputs Control Pulses, Step Resolution, Reset, Boost, Deactivate and Deselect are optically insulated from the motor supply voltage by optocoupler. This assures best noise suppression between control and power circuit.

The signals are active, when current flows through the optocoupler. The controlling via push-pull driver confers optimum suppression of disturbances, because always the current flows. Specially in case of long leads this kind of controlling should be preferred.

Depending on the CCD⁺ version the input level is 5 V or 24 V.

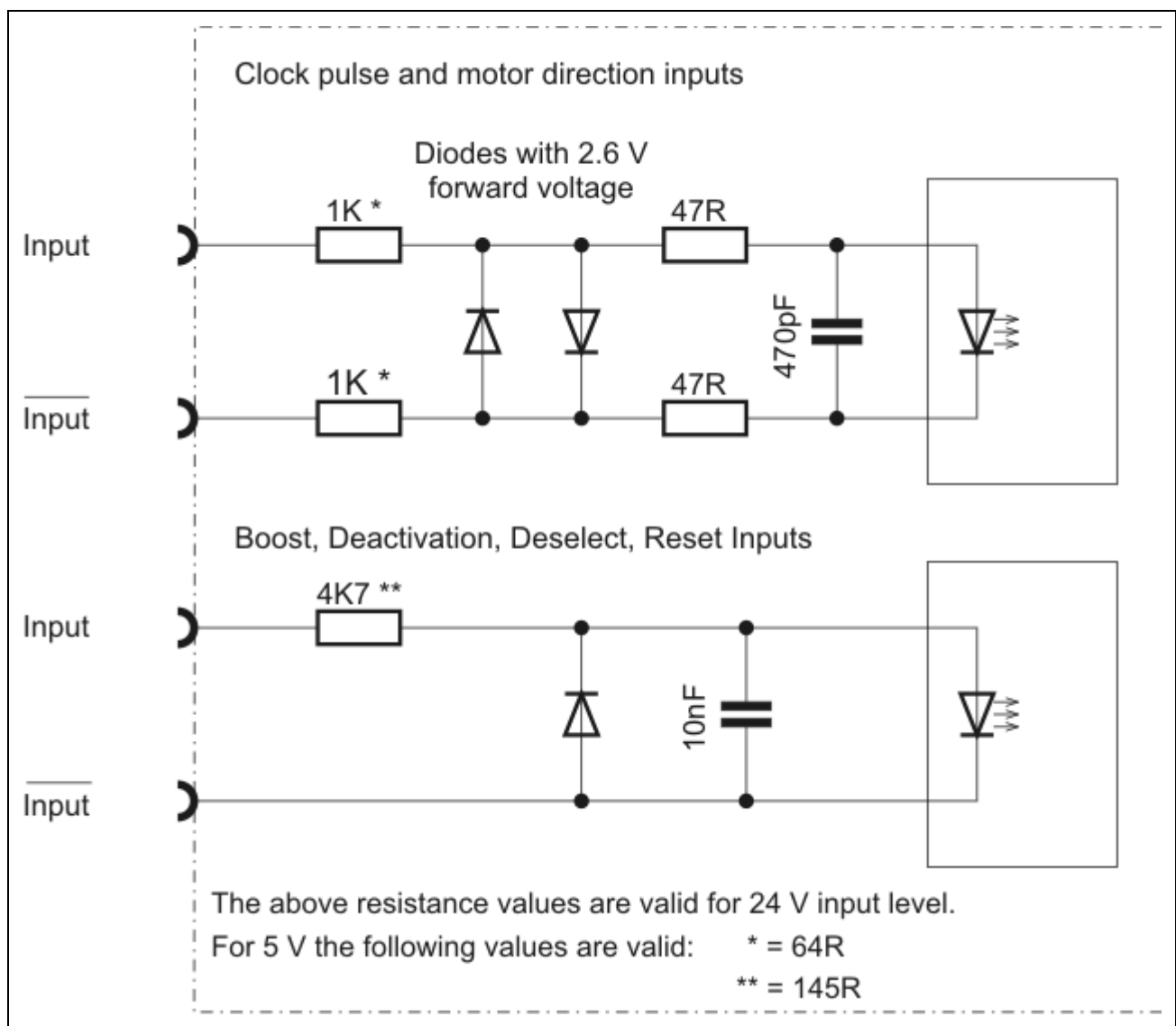

Fig. 17: Input wiring diagram

Manual CCD+

7.2.1 Push-Pull- or Open Collector-Controlling

We recommend to control the CCD+ inputs by push-pull drivers. This confers optimum suppression of disturbances.

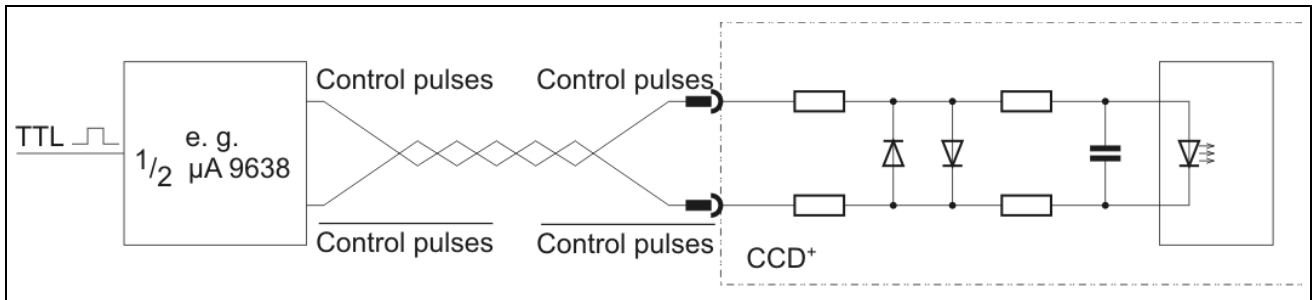

Fig. 18: Push-pull controlling

Alternatively a controlling via open-collector is possible.

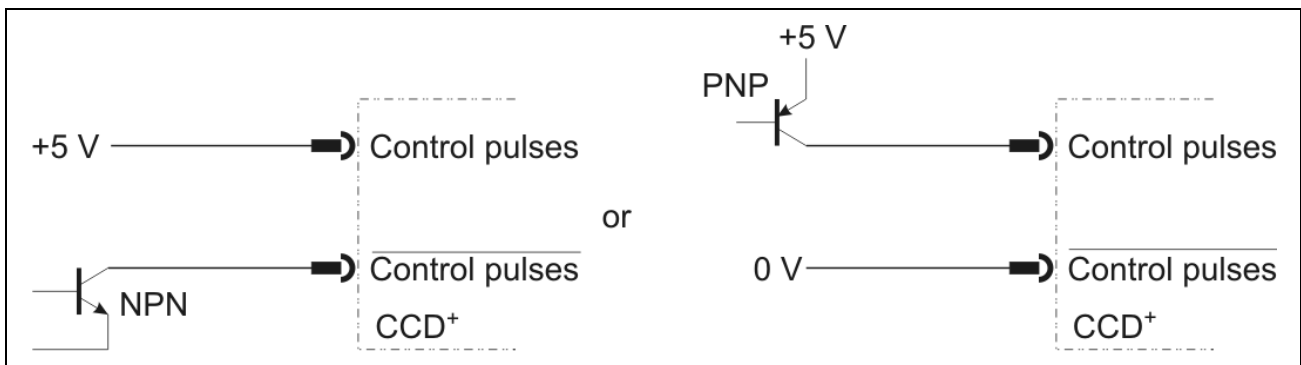

Fig. 19: Open-Collector Controlling

7.2.2 Logic-Level 24 V or 5 V

CCD+ power stages are available in two versions with input level 5 V or 24 V.

The input level can also be changed subsequent on demand.

Signalpegel	5 V	24 V
High	3 – 5.5 V	20 – 30 V
Low	< 0.4 V	< 3 V
Necessary driver current	max. 10 mA (at 3 V)	max. 10 mA (at 20 V)
	max. 30 mA (at 5.5 V)	max. 20 mA (at 30 V)

7.2.3 Control Pulses

Maximum pulse frequency: 250 kHz

Minimum pulse width 2µs

The step is done with the falling flank of the control pulse.

The control pulse sequency must not suddenly start or stop, if the control pulse frequency is higher than the start/stop frequency¹ of the motor. Mispositioning of the drive would be the result.

If the motor is to be operated above the start/stop frequency range, the indexer has to generate frequency ramps to accelerate and decelerate the motor.

Current delay time

After the last control pulse the stop current is activated after a waiting time. The waiting time after the last control pulse until the changing to the stop current is called current delay time. The current delay time can be set in the SETUP menu, the default value is 40 msec.

Warning:

As long as the BOOST input is energized, **always** the motor current will be the BOOST current.

Although no control pulses arrive, the stop current is **not** activated!

7.2.4 Direction

If the input optocoupler is powered, the selected motor direction of rotation is reversed. Don't change the signal 1 µsec before the rising flank and after the falling flank of the control pulse!

7.2.5 Boost

If the input optocoupler is energized the CCD⁺ sets the current to the selected value for the BOOST current. Therefore it is possible, to set a BOOST current, which is higher than the run current.

Thus, a higher torque can be reached during the acceleration and deceleration time of the motor.

As long as the BOOST input is energized, **always** the motor current will be the BOOST current. **No change to the stop current!**

¹ The start/stop frequency is defined as that frequency, from which a stepper motor can start from standstill without losing a step. Typical values for the start/stop frequency are 200 to 2000 Hz. The exact value depends on the motor and the mechanical system. The higher the load inertia and the larger the motor, the smaller is the start/stop frequency.

Manual CCD+

7.2.6 Deactivation

If the input opto coupler is energized, the motor current is switched off.

This input is useful, for instance, during maintenance operations to switch the power stage off, without having to disconnect it physically from the mains. It is possible now to slowly rotate the motor by hand.



WARNING!

The „Deactivation“ input is not on conformance with the professional emergency stop circuit requirements.

The input „Deactivation“ may also be used to avoid the inevitable electrical noise emissions of the power stage, e.g. if you have to perform sensitive electrical measurements in the environment of the device.

7.2.7 Deselect

If the input opto coupler is energized, the pulse inhibit is active.

If the input is not connected, the CCD+ is ready for work.

7.2.8 Reset

If the input opto coupler is energized, all error signals are reset and the monitoring circuits are initialized.

After cut-off the reset signal, the power stage will enable the ready signal after approximately 500 msec.

Remark:

Reset can also be activated by the menu item **RESET** in the **SETUP** menu.

7.3 Outputs

Open-Collector-Darlington outputs insulated by means of opto coupler

$I_{\max} = 20 \text{ mA}$, $U_{\max} = 30 \text{ V}$, $U_{CE \text{ sat}} \text{ bei } 20 \text{ mA} < 1 \text{ V}$

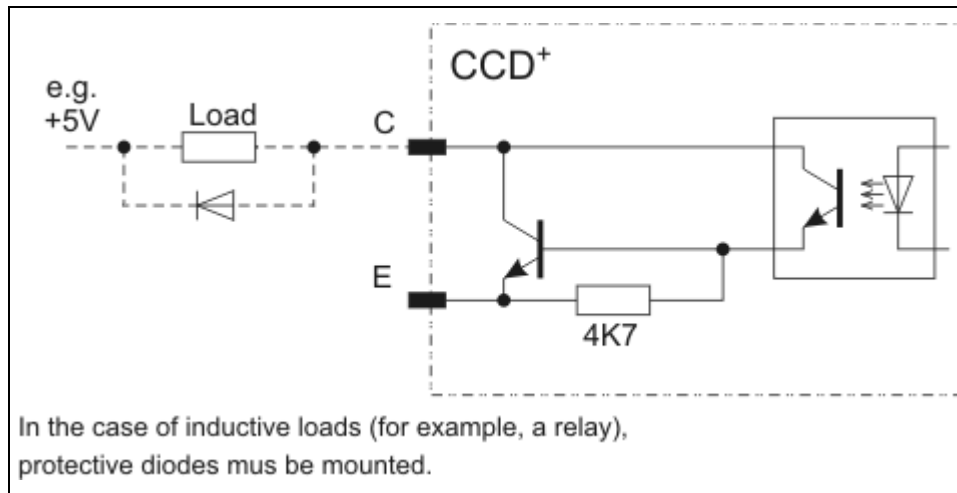

Fig. 20: Output wiring diagram

7.3.1 Ready

The CCD⁺ is ready, when the output „Ready“ is activated (current is flowing). The power stage should be activated, that means that the input „Deactivation“ should be powered off. See also chap.7.2.6.

7.3.2 Error

This output opens at the error messages: under voltage, over current / short circuit, over temperature. At the same time the drive system is deactivated to avoid damages.

An error message can be reset after error elimination or cooling. Hereto the menu item **RESET** should be selected in the test menu and verified with OK. The CCD⁺ can also be reset by the input Reset.

After cut-off the reset signal, the power stage will enable the ready signal after approximately 500 msec.

Under voltage

The under voltage identification starts as soon as the supply voltage drops under $17 V_{DC}$. This error message can also occur if an external supply voltage of 24 V (AC or DC) breaks down under load for a short time. In case of AC or pulsating DC power supply the voltage rigidity at the transformer is not high enough (the voltage drop may occur due to a high resistance in the secondary transformer winding).

In case of power supply, typical reasons for low voltage error messages are internal load limiters or small load capacitors in the power supply.

Over current / Short circuit

Short circuit occurs:

- from phase to phase
- phase to ground
- within a motor phase

Check the connector wiring.

Check the motor cable for short circuits.

Disconnect the motor and check it for any short circuits by measuring the insulation (phase to phase, phase to GND, phase to motor cage).

Over temperature Power Stage

The temperature at the heat sink of the power transistors reaches the limit value ($> 85^{\circ} C$). At the same time the power stage is powered off.

8 The Menu

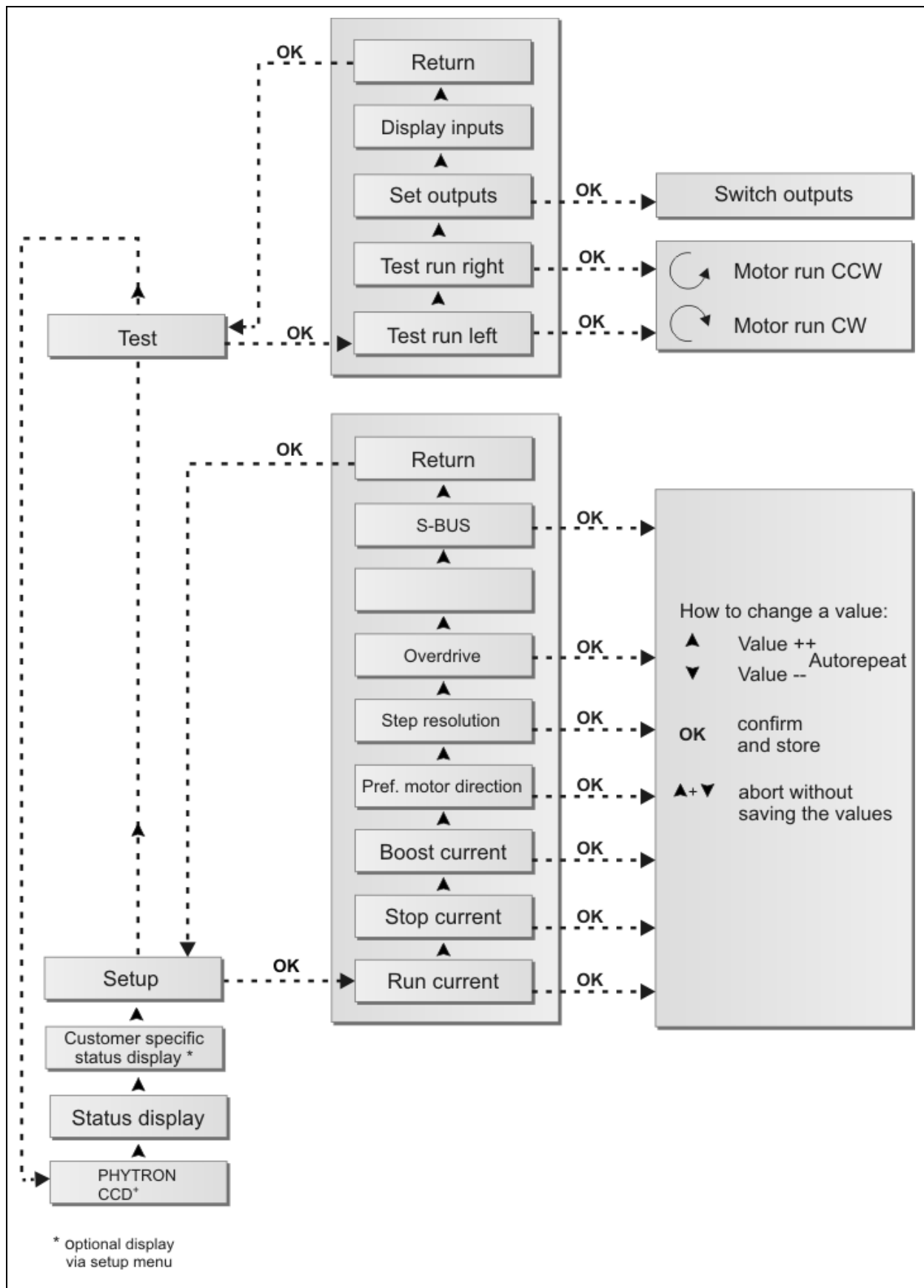

Fig. 21: Structogram of the menu

8.1 Menu Function Test



Read the safety instructions in chapter 3.2 before installing the CCD+.

1. First connect **only the current supply**.
2. Set the motor currents in the SETUP menu, see above. Excessively high motor currents may overheat or damage the motor windings.
3. Power off the device.
4. Connect the stepper motor.
5. Switch on the power supply of the CCD+.
6. Test the menu functions shown in Fig. 16 and the stepper motor should turn. This functions can be done without connecting a superior control.
7. Mount the CCD+ in the switching cabinet for operation (chap. 4)
Control pulse- and direction signals have to be connected at least (Chap. 7).

8.2 Main Menu

After turning on the supply voltage, the following text will appear in the LCD display: **PHYTRON CCD+**. With the button ▲ and ▼ of the menu all items of the upper menu level can be selected: Status display, Setup, Test, customer specific status displays.

Changes of parameters during motor operation cause the display message **! MOTOR RUNNING**.

Menu display	Meaning
Status display	This stop current flows, when a stepper motor is connected. If the stepper motor runs, the run current or the boost current is displayed. Before connecting the stepper motor the motor currents must set to fitting motor values ! → SETUP
Customer specific Status display	Two additional Status displays in the main menu: DISP 1 and DISP 2 In the SETUP menu you can select, the parameters to be displayed. I + U = motor current (reference value) + supply voltage I + M = motor current (reference value) + motor current (actual value) I + T = motor current (reference value) + power stage temperature TEMP = power stage temperature + motor temperature

8.3 Setup

Changing the operating parameters:

1. With the button OK the sub menu for positioning is activated.
2. Changing the value with the buttons: ▲ (higher) or ▼ (lower).
3. With OK the value is confirmed and the sub menu quitted.
4. Interrupting the edit mode: press the buttons ▲ and ▼ in one operation.

The display of power stage temperature, motor voltage and software version can be activated in the SETUP menu.

N/A= not available

8.3.1 Menu Items in the Setup Menu

With the buttons ▲ and ▼ you can scroll up and down from item to item:

Menu item	Meaning
I-RUN = x.x A I-STOP = x.x A IBOOST = x.x A	Setting of run-, stop- and Boos current in $A_{r.m.s.}$
IDELAY	Current delay time in msec It is a proved method to keep to the run current level for a short time after the last step pulse arrived, and after that reduce to stop current level.
DEFDIR	The motor turns in preferred direction of rotation DEF inition DIR ection, if there is no direction signal to change the direction. CW = clockwise CCW = counter clockwise
MINIST	Setting of the step resolution MINIST ep FULL = Full step, HALF = Half step, 1/2.5 step, 1/8 step, 1/10 step , 1/8 step, 1/20 step
OVERDR	Activation of the Overdrive function: ON or OFF
PSTEMP	Display of the power stage temperature in °C
VOLT	Display of the motor current in V
LCDCTR	Display contrast from 0 to 100 in steps of 5 (e.g. 5 = miner contrast, 90 = higher contrast)

Manual CCD+

TSENS¹	N/A
TMOTOR¹	N/A
TLIM1,TLIM2,TLIM3¹	N/A
DEGAS¹	N/A
DISP1,DISP2	<p>Customer specific status display</p> <p>NONE: No item is selected.</p> <p>A list of display parameters, from which you can select; a list of display parameters appears, from which you can select:</p> <p>I + U = motor current (reference value) + operating voltage</p> <p>I + M = motor current (reference value) + motor current (actual value)</p> <p>I + T = motor current (reference value) + power stage temperature</p> <p>TEMP = power stages temperature- (TE) + motor temperature (TM)</p> <p>Enter OK to confirm the input. The selected parameters, for example motor current and power stage temperature can be displayed permanently on the main menu.</p> <p>NOSENS: the display motor temperature is set, although no temperature monitoring module is built-in</p>
PASSWO	<p>Lock the SETUP and test menu and prevent unauthorized access</p> <p>If OK is pressed, the letter A appears on display. If you want to inhibit the access, confirm with OK.</p> <p>For allowing again the access, select the letter P with the button and confirm with OK.</p> <p>PASSWO FALSE is on display, if an inaccessible menu item is selected.</p>
S-BUS	<p>Activation of the operation mode ServiceBus</p> <p>ENABLED: ServiceBus on. The operating parameters can only be regulated by ServiceBus-Comm. The adjusted parameters and status values are shown on the CCD⁺ display.</p> <p>Remark: If the power stage is set to bus mode exclusive in the ServiceBus mode, all settings are ignored at the menu buttons. The ServiceBus mode can only be deactivated by the ‚PX‘ instruction code.</p>

¹ provided for further development: connection of a temperature sensor

	DISABLED: ServiceBus off. The operating parameters are configured by the menu driven input.
SW-V.	The actual version number is shown.
RETURN	The last menu item in the SETUP menu.

 = Values **only** shown on the display

Return to menu item run current by pressing button ▲ . If you confirm with OK, the SETUP menu is quitted.

8.3.2 Password Protection

If the password protection is activated, the set-up in the SETUP menu and the test menu are protected against unauthorized access.

PASSWO FALSE is on display, if an inaccessible menu item is selected.

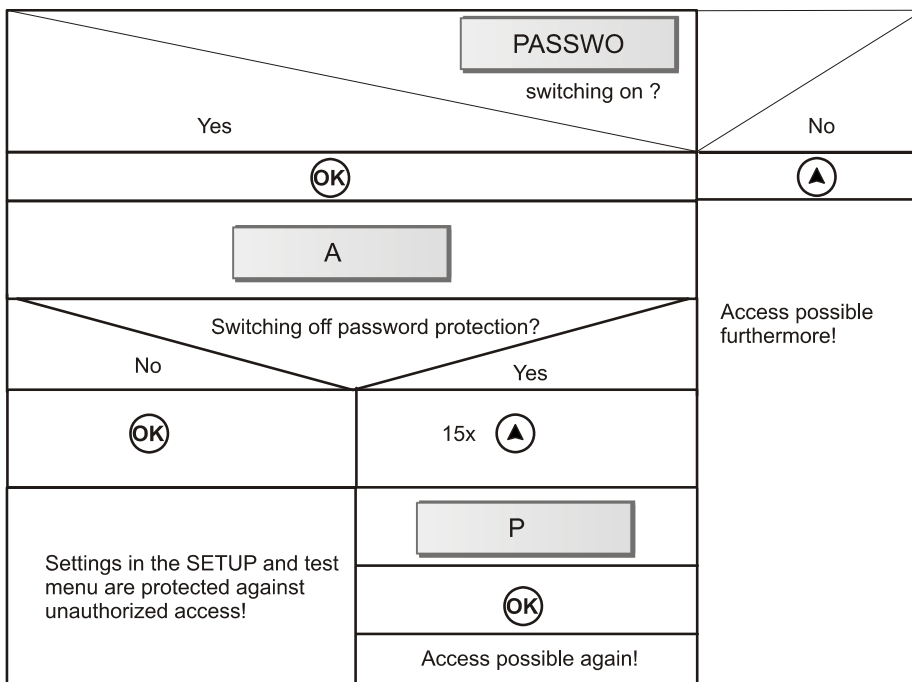

Manual CCD+

8.4 Test

The menu item **TEST** contains several sub menu items, which can be selected with the arrow buttons.

Menu item	Meaning												
TESTCCW TESTCW	<p>Test run: A connected stepper motor turns (slowly) by pressing the button OK. The motor turns, as long as the button OK is pressed.</p> <p>CCW counter clockwise CW clockwise</p>												
TESTOUT _{puts}	<p>Display and edit the Output status</p> <p>e.g.: e R t2 t1 Small letter: output not set Capital letter: output set</p> <p>In our example: e = Error not set R = Ready set t2 = Temperature warning 2 not set t1 = Temperature warning 1 not set</p> <p>The flashing letter can be changed by pressing the button ▼ e ↔ E. By pressing the button ▲ the next letter can be selected. If you confirm with OK, the changes are saved.</p>												
TESTIN _{puts}	<p>Input status display</p> <p>e.g.: A b S d r</p> <table border="0"> <tr> <td>A = power stage activated</td> <td>Inputs:</td> </tr> <tr> <td>b = no Boost</td> <td>Entregen not active</td> </tr> <tr> <td>S = power stage selected</td> <td>Boost not active</td> </tr> <tr> <td>d = preferred motor direction</td> <td>Deselect not active</td> </tr> <tr> <td>r = no reset</td> <td>Motor direction not active</td> </tr> <tr> <td></td> <td>Reset not active</td> </tr> </table> <p>Remark: The CCD+ is set up in this example with the input and output status, that the motor should turn, as soon as control pulses arrive (or a test run is started).</p>	A = power stage activated	Inputs:	b = no Boost	Entregen not active	S = power stage selected	Boost not active	d = preferred motor direction	Deselect not active	r = no reset	Motor direction not active		Reset not active
A = power stage activated	Inputs:												
b = no Boost	Entregen not active												
S = power stage selected	Boost not active												
d = preferred motor direction	Deselect not active												
r = no reset	Motor direction not active												
	Reset not active												
RESET	<p>Power stage reset</p> <p>The Reset is done, if the button OK is pressed. With the input Reset the power stage can also be reset.</p>												
RETURN	The last menu item in the test menu												

With the button ▲ you return to the menu item test run. If you confirm with OK, the test menu is quitted.

8.5 Error Messages

If an error occurs, the error message is shown on the display alternately with the status:

ERROR CURR-LIM	short circuit
ERROR TEMP-LIM	over temperature
ERROR LOW-VOLT	under voltage < 17 V
MOTOR RUNNING	This error message appears, if you try to change parameters during the motor runs.
PASSWO FALSE	The access on this menu item is inhibited.

If there are several errors **at the same time** the error message with the highest priority is shown.

An error message can be reset after elimination of the error conditions resp. cooling. Select the menu item **RESET** in the test menu and confirm with OK. With the input Reset the power stage can also be reset.

8.6 Trouble-Shooting

The following sample point collection will help you to eliminate eventual faults:

Problem: Changes in the SETUP menu or test menu not possible

Display: **PASSWO FALSE**

The password protection is active. Select the menu item **PASSWORD** in the SETUP menu. Press the button OK. Now appears the letter **A**. Select with the arrow button the letter **P** and confirm with OK. The password protection is now deactivated.

Problem: Display bad readable

Change the display contrast in the menu item **LCDCT**.

Problem: Display dark

Eventually the temperature in the switching cabinet is too high.

Problem: Error message over temperature

Check the ventilation (see chap. 4.2) and current setups (see chap. 5.6). Mount a ventilator.

Problem: Motor does not run.

1. Check the current setups. At delivery run current and boost current are set to 1 A.
2. Check the cable and the correct mounting of the connectors.

Problem: Motor becomes very hot

Check the current setups. Eventually the set run current or the boost current is too high for the motor winding. The stop current should be set to above 50% of the run current.

As long as the input BOOST is active, **always** the set BOOST current flows. Even if there are no Control Pulses, the stop current is **not** activated!

9 ServiceBus Connection

The operation parameters in the CCD⁺ can be set by the serial bus connection (ServiceBus). The instruction set and other information about ServiceBus can be read in the manual 'Instruction Set for Stepper Motor Power Stages with ServiceBus'.

ServiceBus displays:

- S-BUS DISABLED** ServiceBus is deactivated. The operation parameters are set by the menu driven input.
- S-BUS ENABLED** ServiceBus is activated and can be deactivated by the menu buttons. Parameter settings are only possible by the ServiceBus.
- S-BUS LOCKED** The power stage is set to bus mode exclusive by ServiceBus-Comm. All settings with the menu buttons are ignored and only possible by ServiceBus.
Leaving this mode is only possible by ServiceBus with the 'PX' instruction code.

9.1 ServiceBus Interface

CCD⁺ and PC can be directly connected by the USB cable type A-B. The USB port of the PC (type A) is directly connected to the USB port of the power stage (type B).

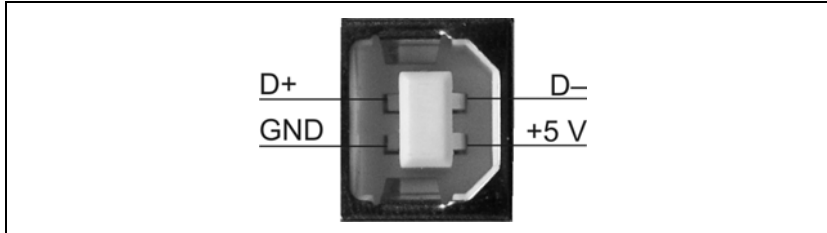

Fig. 22: ServiceBus connector at the bottom of the housing
USB port type B (DIN IEC 61076-3-108)

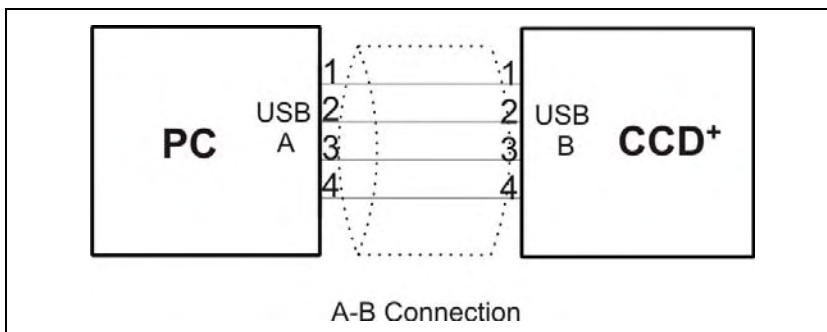

Fig. 23: Wiring scheme PC <--> CCD⁺ by cable type A-B

Important: The corresponding USB drivers, which are stored on the phytron CD, must be installed on the PC, if the USB interface is used.

9.2 USB Driver Installation

Important: Administrator authorizations are requested for driver installation.

- Power on your PC. Insert the phytron CD and open the folder **USB Driver** by the Windows Explorer. Select the **.exe** program which goes with your system software and start it by double click. The following window is shown on desktop after a successful installation:

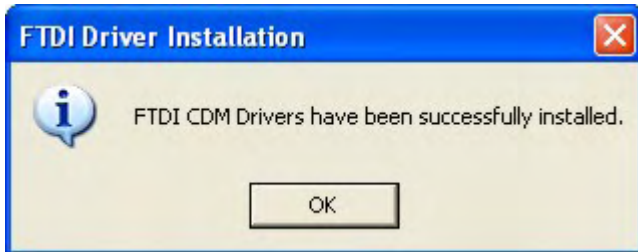

- Connect the power stage directly or via USB converter to the USB port of your PC by USB cable.

Important: Use a USB cable with a maximum length of 2 m!

- For checking the correct USB driver installation, continue as follows:

Start the device manager by clicking **Start→Settings→System control** and double-click on **System**. Then select the **Device manager** tab. The USB components can be found in **Computer→Ports** and in **Universal Serial Bus Controller**. Here the new USB-component is shown: **USB Serial Port (Com X)**

- **Important:** If you want to test several USB devices, which are identical in construction, you should use the same USB port on the PC. Thus, you avoid to change the COM port number.
- You'll also find information about the driver installation for the chip FT232R on <http://www.ftdichip.com>.

Appendix A: Technical Details

A stepper motor can be used with different step resolutions, which are described in the first part of this chapter. The functions Boost, Overdrive, Current delay time and the Current Shaping you'll find in the second part.

A1 Full Step / Half Step / Ministep

Full Step (FS)

The FULL STEP mode is the operating mode in which a 200-step motor, for example, drives 200 steps per revolution. In the full step mode, both stepper motor phases are permanently energized.

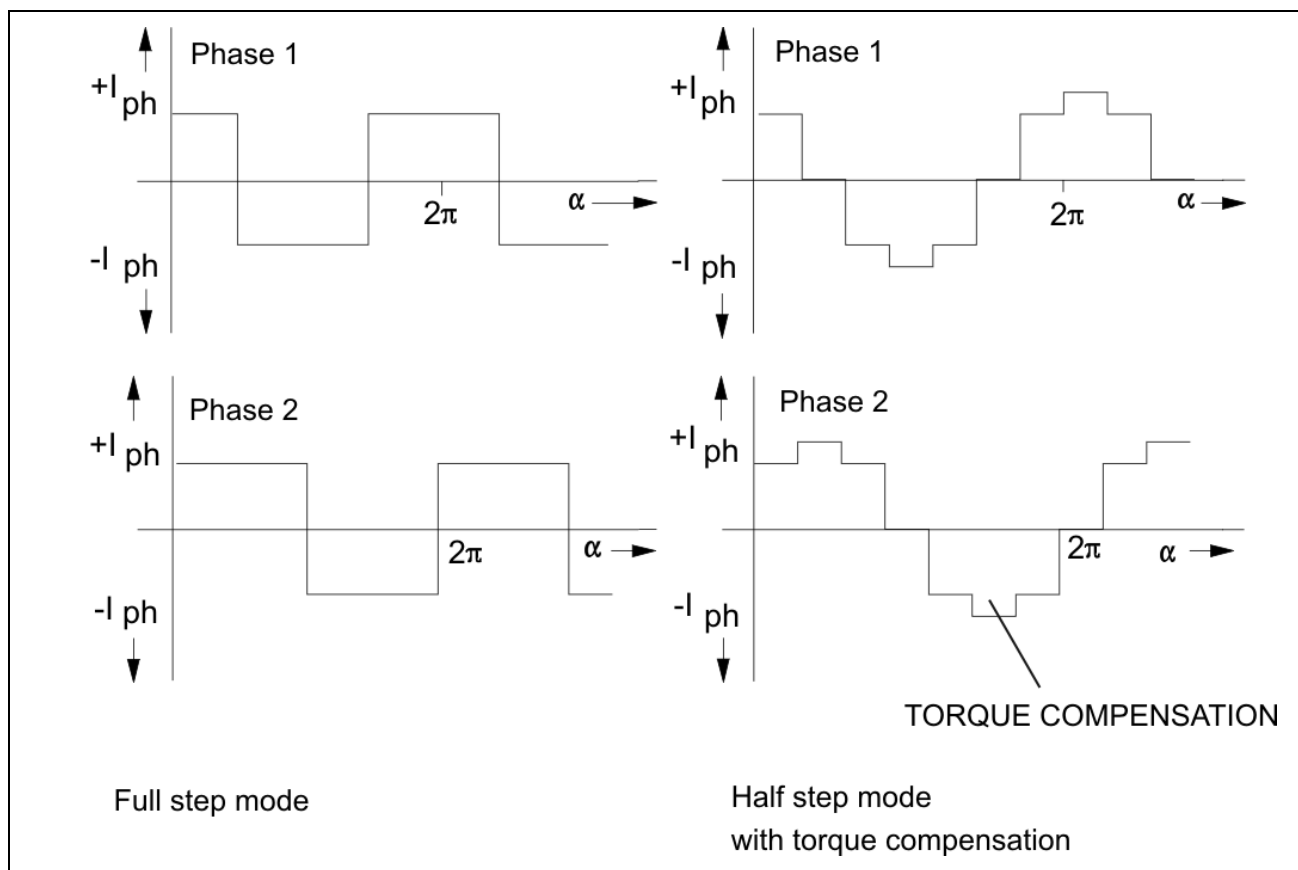

Fig. 24: Phase current curves

Manual CCD+

Half step (HS)

The motor step resolution can be electronically multiplied by 2 by alternately energizing the stepper motor's phases 1, 1+2, 2 etc. This is the HALF STEP mode. The torque, however, is reduced in the half step mode, compared to the full step mode.

To compensate this lack of torque, the operating mode HALF STEP MODE WITH TORQUE COMPENSATION was developed: the current is increased by $\sqrt{2}$ in the active phase. Compared to the full step mode, the torque delivered is almost the same. Most of the resonance is suppressed.

The following diagram shows extent and direction of the holding torques of a 4-step motor during one revolution without and with torque compensation. In the full step position two phases, in the half step position only one phase is energized. The total moment is the result of superpositioning both phase moments.

The moment in the full step mode, M_{FS} , as compared to the moment in the half-step mode, M_{HS} is: $|M_{FS}| = |M_{HS}| \times \sqrt{2}$

This means, when a single phase is energized, the current must be increased by a $\sqrt{2}$ factor to obtain an identical torque.

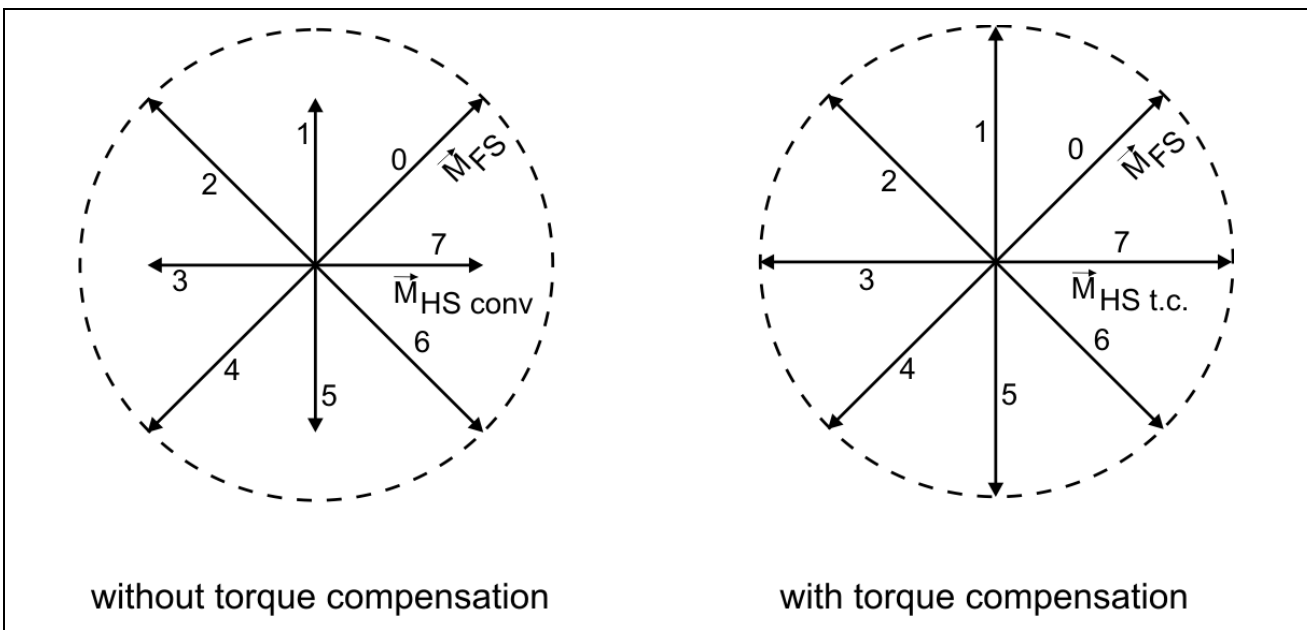

Fig. 25: Holding torques without/with torque compensation

Ministep

When used in the „ministep mode“, the power stage CCD⁺ increases the step resolution by a factor 2½, 4, 5, 8, 10, 16 or 20.

Various advantages are obtained by the mini-step mode:

- The torque undulation drops when the number of ministeps is increased.
- Resonance and overshoot phenomenae are greatly reduced; the motor operation is almost resonance-free.
- The motor noise also drops when the number of ministeps is increased.

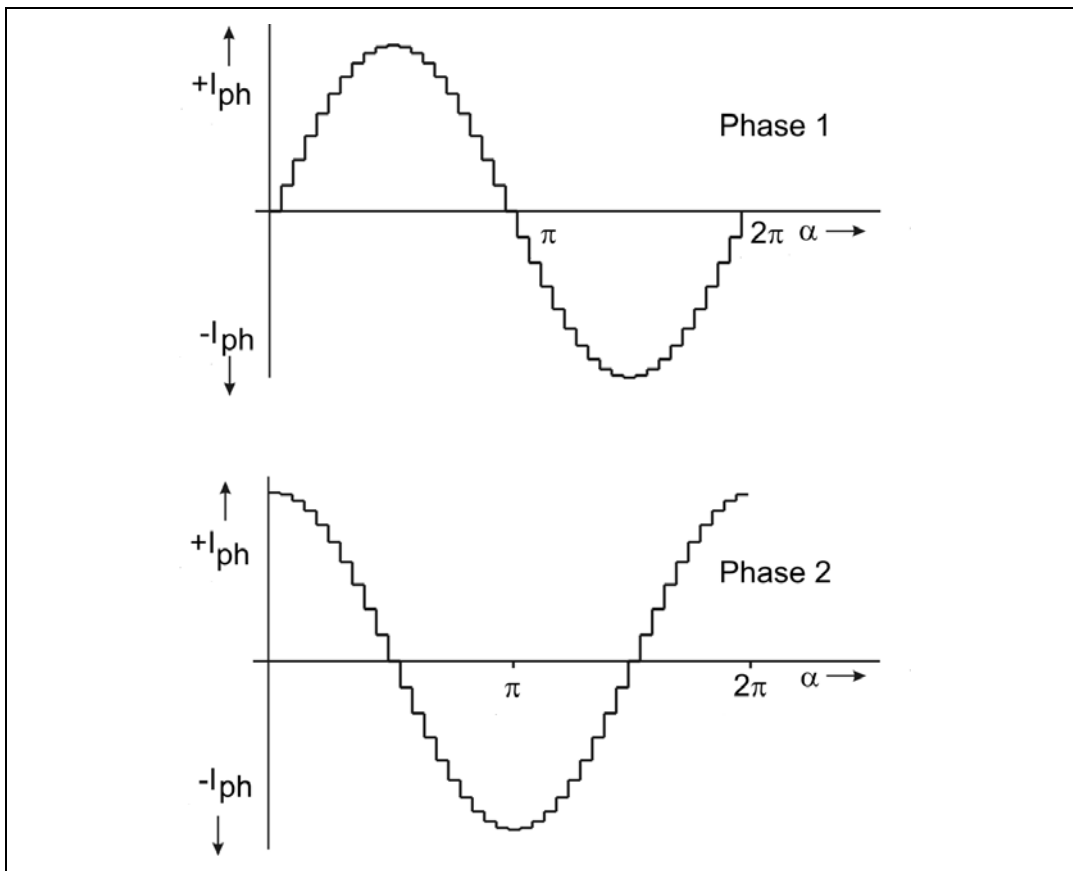

Fig. 26: Ministep 1/10 (of a Full step)

A2 Boost

The motor torque required during acceleration and deceleration is higher than that required during continuous motor operation (f_{\max}). For fast acceleration and deceleration settings, (steep ramps), the motor current is too high during continuous operation and results in motor overheating. However, a lower phase current results in too flat acceleration and deceleration ramps.

Therefore, different phase currents should be used:

- Continuous operation: run current
- During acceleration and deceleration: BOOST current

The BOOST signal is activated by the superior controller. While input „BOOST“ is energized, the CCD selects the phase current set by the SETUP menu item „BOOST“.

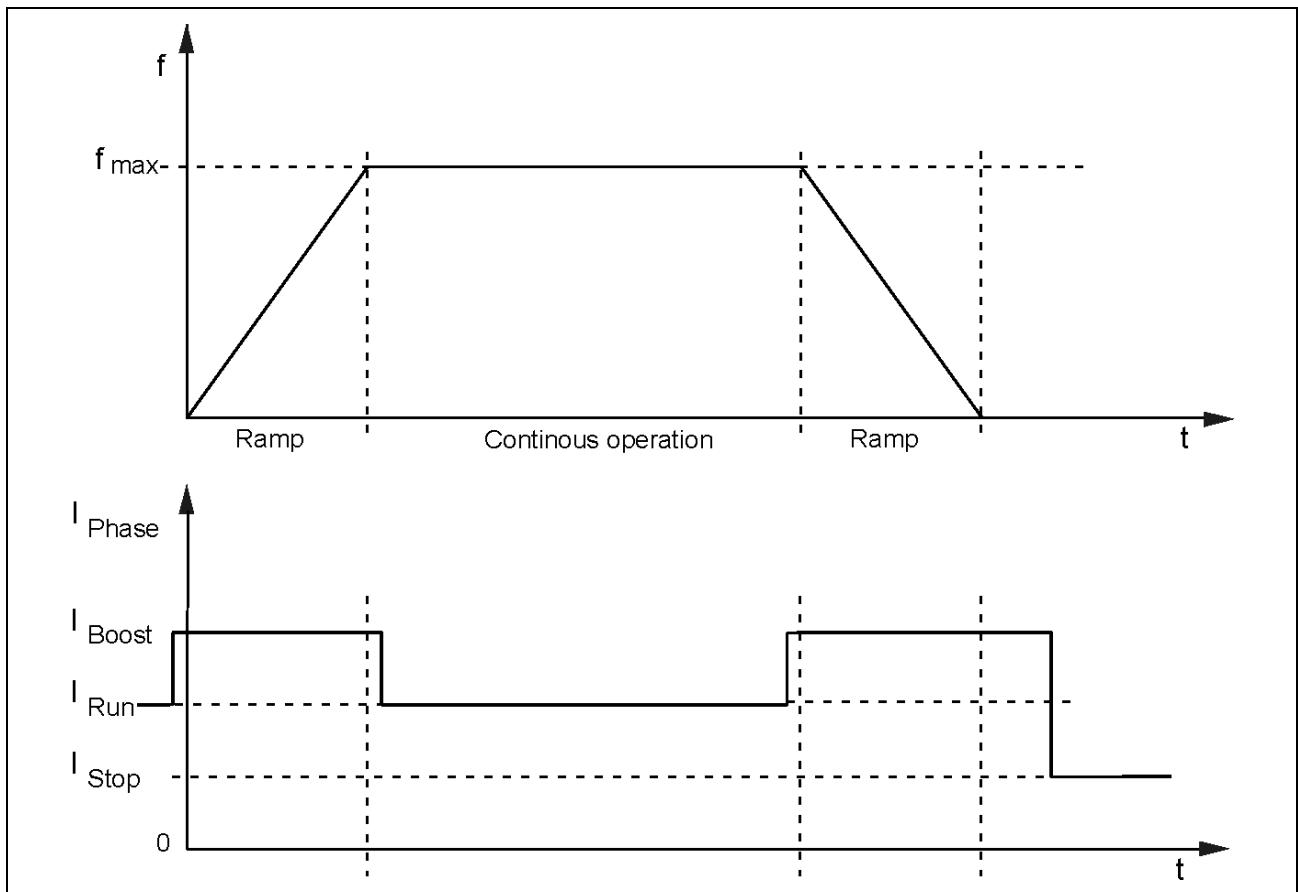

Fig. 27: Boost

A3 Self-Adapting OVERDRIVE

By the OVERDRIVE function, the CCD⁺ power stages can compensate the phase current decrease in the upper speed range. OVERDRIVE is self-adapting and therefore independent on the motor type.

OVERDRIVE is a dynamic boost function, which will be automatically switched on if this makes sense in regard of the current shape:

The stepper motor phase current decreases with increasing step frequency caused by the motor inductivity. Now the CCD⁺ increases the motor current by 20%. This turnover frequency is not fixed, as it is at other stepper motor power stages, but automatically adapted to the individual motor. If the frequency becomes lower again, the OVERDRIVE is switched off again.

The benefit of this is a higher torque in the middle and high frequency ranges.

The function Overdrive is activated on delivery and can be switched off in the ServiceBus mode by ServiceBus-Comm[®] or in the setup menu.

A4 Current Delay Time

After the last control pulse the stop current is activated after a waiting time. The waiting time after the last control pulse until the changing to the stop current is called current delay time.

We recommend to specify t_{Delay} so that the motor's oscillations are dying out after the last motor step and mispositioning is avoided.

In Rotary switch mode the current delay time is set to 40 ms.

In ServiceBus mode the delay time can be programmed from 1 to 1000 ms in 15 steps.

Automatic change from run to stop current:

The ratio between both phase currents remains equal in the respective current feed pattern. Changing from run to stop current is synchronously.

In the following figure the next motor step follows after every **rising** control pulse edge:

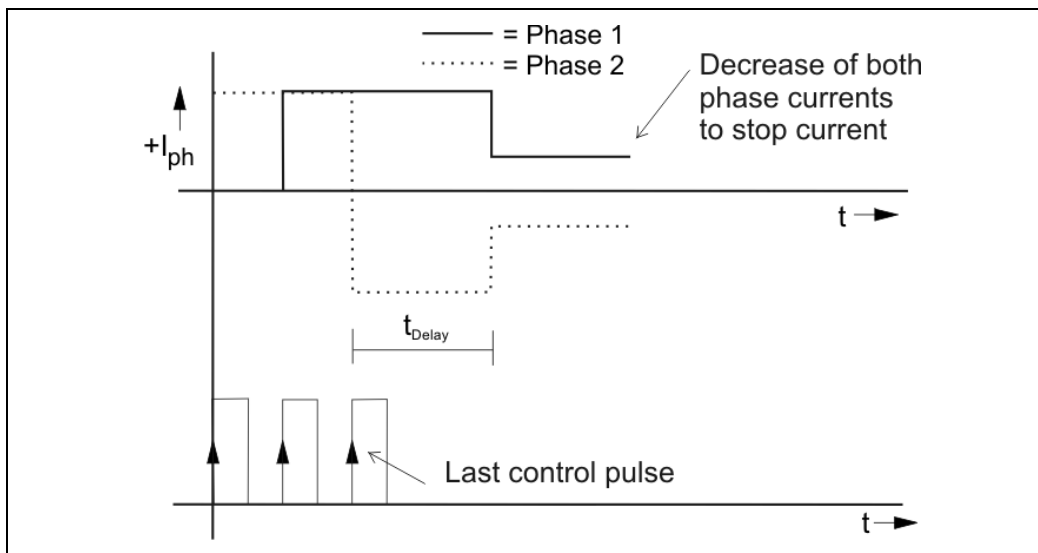

Fig. 28: Decrease to stop current after the last control pulse (full step)

Decreasing to stop current takes the following advantages:

- Motor and power stage heating is reduced.
- EMC is improved because of smaller current values

Appendix B

In this chapter warranty, trade marks and ESD protective measures are described.

B1 Warranty

The CCD⁺ power stages are subject to legal warranty. phytron will repair or exchange devices which show a failure due to defects in material or caused by the production process. This warranty does not include damages which are caused by the customer, as there are, for example, not intended use, unauthorized modifications, wrong treatment or wrong wiring.

B2 Trade Marks

In this manual several trade marks are used which are no longer explicitly marked as trade marks within the text. The lack of this signs may not be used to draw the conclusion that these products are free of rights of third parties. Some product names used herein are for instance

- ServiceBus-Comm is a trade mark of the Phytron-Elektronik GmbH.
- Microsoft is a registered trade mark and WINDOWS is a trade mark of the Microsoft Corporation in the USA and other countries.

B3 ESD-Protective Measures

All the products which we deliver have been carefully checked and submitted to a longterm test. To avoid the failure of components sensitive to electrostatic discharge (ESD), we apply a great number of protective measures during manufacturing, from the component input check until the delivery of the finished products.

Warning:

Manipulation of ESD sensitive devices must be effected by respecting special protective measures (EN 61340–5). Only return the modules or boards in adapted packaging.

phytron's warranty is cancelled in case of damages arising from improper manipulation or transportation of ESD modules and components.

Appendix C: Declarations of Conformity

Phytron-Elektronik GmbH

EG-Konformitätserklärung

Declaration of Conformity

Hiermit erklären wir, dass die Bauart der nachfolgend bezeichneten Produkte in der von uns in Verkehr gebrachten Ausführung den unten genannten einschlägigen EG-Richtlinien entspricht.

We, the manufacturer, declare hereby on our own responsibility, that the following products meet all the provisions of the EU directive cited below:

Produktbezeichnung <i>Part name</i>	Identnummer <i>ID-No.</i>	Ab Serienr. <i>From Serial No</i>
CCD+	10010111, 10010112, 10010113, 10010114	Alle/all

Angewendete EG-Richtlinie / EU Directive Applied:

89/336/EWG vom 3. Mai 1989 (EMV-Richtlinie)
89/336/EEC of May 3rd, 1989 (EMC Directive)

Angewendete harmonisierte Normen / Harmonized Standards Applied:

EN 61000-3-2	2006-10	Elektromagnetische Verträglichkeit (EMV) Grenzwerte für Oberschwingungsströme <i>Limits for harmonic current emissions</i>
EN 61000-6-3	2005-11	Elektromagnetische Verträglichkeit (EMV) Fachgrundnorm Störaussendung - Wohnbereich, Geschäfts- und Gewerbebereiche sowie Kleinbetriebe <i>Electromagnetic compatibility (EMC) - Emission standard for residential, commercial and light-industrial environments</i>
EN 61000-6-4	2002-08	Elektromagnetische Verträglichkeit (EMV) - Fachgrundnorm Störaussendung für Industriebereich <i>Electromagnetic compatibility (EMC) - Emission standard for industrial environments</i>
EN 61000-6-1	2002-08	Elektromagnetische Verträglichkeit (EMV) - Störfestigkeit für Wohnbereich, Geschäfts- und Gewerbebereiche sowie Kleinbetriebe <i>Electromagnetic Compatibility (EMC) - Immunity for residential, commercial and light-industrial environmental</i>
EN 61000-6-2	2002-08	Elektromagnetische Verträglichkeit (EMV) - Störfestigkeit für Industriebereiche <i>Electromagnetic compatibility (EMC) - Immunity for industrial environments</i>

Anmerkung/Comment:

Gröbenzell, den 15. Mai 2008 / Gröbenzell, May 15th, 2008



Heribert Schmid
Technischer Geschäftsführer/ Managing Director

Sitz Gröbenzell · Germany
Kaufm. Geschäftsführer B. Hartmann
Techn. Geschäftsführer H. Schmid
Reg.-Gericht München HRB 44 426
Ust.-IdNr. DE 128242222

Telefon +49 8142 503-0
Fax: +49 8142 503-190
info@phytron.de · www.phytron.de
Industriestraße 12 · 82194 Gröbenzell
Postfach 12 55 · 82180 Gröbenzell

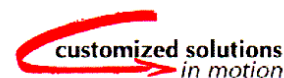

Phytron-Elektronik GmbH

EG-Herstellererklärung

gemäß EG-Richtlinie Maschinen 98/37/EG, Anhang II B

Declaration of Conformity

According to EC Directive on Machinery 98/37/EC, Annex II B

Hiermit erklären wir, dass es sich bei dieser Lieferung um die nachfolgend bezeichnete unvollständige Maschine handelt. Die Inbetriebnahme dieser Maschine/des Maschinenteils ist so lange untersagt, bis festgestellt wurde, dass die Maschine, in die sie eingebaut werden soll, den Bestimmungen der EG-Richtlinien Maschinen 98/37/EG entspricht.

We, the manufacturer, declare that this delivery is for an incomplete machinery as defined below. The start-up of this machine/machine part is prohibited until it has been determined that the machine in which it is to be incorporated complies with the requirements of EC machine guidelines 98/37/EC machine guidelines 98/37/EC.

Produktbezeichnung <i>Part name</i>	Identnummer <i>ID-No.</i>	Ab Seriennr. <i>From Serial No</i>
CCD+	10010111, 10010112, 10010113, 10010114	Alle/all

Angewendete harmonisierte Normen / Harmonized Standards Applied:	
EN 12100-1: 2004-04	Sicherheit von Maschinen - Grundbegriffe, allgemeine Gestaltungsleitsätze - Teil 1: Grundsätzliche Terminologie, Methodologie
EN 12100-2: 2004-04	Sicherheit von Maschinen - Grundbegriffe, allgemeine Gestaltungsleitsätze - Teil 2: Technische Leitsätze
EN 60204-1: 1998-11	Sicherheit von Maschinen - Elektrische Ausrüstung von Maschinen - Teil 1: Allgemeine Anforderungen

Anmerkung/Comment:

Diese Erklärung verliert ihre Gültigkeit bei baulicher Veränderung und bei nicht bestimmungsgemäßer Verwendung, sofern nicht ausdrücklich die schriftliche Zustimmung des Herstellers vorliegt.

This declaration loses its validity as a result of structural alterations and/or use other than defined, unless the express written approval of the manufacturer is present.

Gröbenzell, den 15. Mai 2008 / Gröbenzell, May 15th, 2008



Heribert Schmid
Technischer Geschäftsführer/ Managing Director

Sitz Gröbenzell · Germany
Kaufm. Geschäftsführer B. Hartmann
Techn. Geschäftsführer H. Schmid
Reg.-Gericht München HRB 44 426
Ust.-IdNr. DE 128242222

Telefon +49 8142 503-0
Fax: +49 8142 503-190
info@phytron.de · www.phytron.de
Industriestraße 12 · 82194 Gröbenzell
Postfach 12 55 · 82180 Gröbenzell

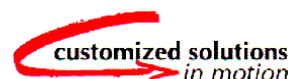

Index

A

AC voltage 5, 24
Ambient temperature 19

B

Base insulation 10
Boost 11, 33, 50
Bus mode exclusive 8, 45

C

Cable cross-section 10
CCW 39
Conditions of delivery 9
Connector 11
Control inputs 31
Control pulses 11
Cooling 19
Copyright 2
Current consumption 25
Current delay time 33, 52
CW 39

D

DC voltage 5, 23
Deactivation 11, 34
Declarations of conformity 54
Default values 9
De-Rating diagram 19
Deselect 12, 34
Dimensions 4
Duty cycle 25

E

Earthing screw 28
EMC 29
Error 12
Error message 43
ESD protective measures 53

F

Fan 10, 20
Full step 47
Fuse 10

H

Half step 47, 48

I

Inductivity 26
Input level 30, 32
Input wiring diagram 31
Inputs 11
Insulation 11

L

Low voltage error 23

M

Mating connector 7
Menu 4, 37
Menu functions 38
Mini step 49
Minimum technical spaces 10
Motor cable 25, 28
Motor cable length 9
Motor connection 26
Motor direction 11, 33, 39
Mounting 10
Mounting instructions 17
Mounting screw 17, 20

O

Operating mode 8
Operator's control 4
Outputs 12, 35
Overdrive function 5

P

Parallel 26
Password protection 41
Peak current 25
Phase currents 9
Programming 6
Protective measure 15
Pulse frequency 33
Pulse width 33
Push-pull driver 31

R

Rail mounting 7
Ready 12, 35
Rectifier 5
Reset 12, 34, 42
Resistance 26
Resonance 48, 49
RS 422 5

S

Safety instructions 13
Serial 26
ServiceBus 6, 8, 45
ServiceBus-Comm[®] 7
Setup 39
Shielding mesh 29
Short circuit 36
Signal level 11
Site 10
Start/Stop frequency 33
Status display 38
Step resolution 9, 47
Stepper motor 9, 26
Strain relief 21
Supply voltage 4, 10
Surrounding temperature 10

T

Technical Data 9
Touch voltage 16, 21
Trade marks 53
Transformer 10, 21

U

Under voltage 36
Undervoltage 10
USB driver 46
USB port 46

V

Ventilation 19

W

Warranty 53
Weight 10
Winding inductivity 26
Winding resistance 26

X

X1 21
X2 26
X3 30
X4 30

Phytron-Elektronik GmbH • Industriestraße 12 • 82194 Gröbenzell, Germany
Tel. +49(0)8142/503-0 • Fax +49(0)8142/503-190 • E-Mail info@phytron.de • www.phytron.de

Phytron, Inc. • 600 Blair Park Road Suite 220 • Williston, VT 05495 USA
Tel. +1-802-872-1600 • Fax +1-802-872-0311 • Email info@phytron.com • www.phytron.com